

جامعة الجزائر

كلية العلوم الإقتصادية و علوم التسيير

قسم: علوم التسيير

فرع: إدارة أعمال

الموضوع :

أهمية تقييم أداء العاملين في تدعيم أداء المؤسسة

دراسة حالة :- المؤسسة الوطنية للكهرباء والغاز [سونلغاز]

مذكرة مقدمة ضمن متطلبات نيل شهادة الماجستير

في علوم التسيير تخصص إدارة أعمال

بإشراف الدكتور:

* علي عبد الله

لجنة المناقشة:

د. علي خليلد..... رئيساً

د. علي عبد الله..... مقررأ

د. قدور بوزيدي..... عضواً

د. أحمد زغدار..... عضواً

د. بشير كشرود..... عضواً

من إعداد الطالبة :

➤ نعيمة فضيل

2006-2005

جامعة الجزائر

كلية العلوم الاقتصادية و علوم التسيير

قسم: علوم التسيير

فرع: إدارة أعمال

ملخص حول موضوع:
أهمية تقييم أداء العاملين في تدعيم أداء المؤسسة

دراسة حالة: المؤسسة الوطنية للكهرباء والغاز (سونغاز)

ملخص مقدم ضمن متطلبات نيل شهادة الماجستير

في علوم التسيير تخصص إدارة أعمال

بإشراف الدكتور:

* علي عبد الله

لجنة المناقشة:

د. علي خليلد..... رئيساً

د. علي عبد الله..... مقررأ

د. قدور بوزيدي..... عضواً

د. أحمد زغدار..... عضواً

د. بشير كشرود..... عضواً

من إعداد الطالبة :

➤ نعيمة فضيل

2006-2005

كلمة شكر

الله

«

»

-19-

بادئاً ببدء أحمد وأشكر المولى جل شأنه بديع السموات والأرض أن شق سمعي وبصري بحوله وقوته وفضله وتوفيقه في إخراج هذا الجهد والعمل إلى النور، والذي يعد قطرة من بحر .

كما أتفضل بشكري الخالص وجزيل الامتنان إلى الأستاذ المشرف الدكتور : علي عبد الله الذي كان بمثابة الأب حيث لم يبخل عليّ بجهد المتواصل وأفكاره النيرة وتوجيهاته وإرشاداته السديدة وآرائه القيمة وطريقته المثلى في إدارة التحفيز المعنوي وذلك بتخصيصه لي الأوقات الثمينة من أجل إثراء هذا العمل، فشكراً لك أيها الأستاذ الرمز.

دون أن يفوتني أن أشكر المؤطرة الفاضلة أختي في الله أحلام حباس بسونلغاز على المجهودات الجبارة والمعلومات القيمة التي ساهمت في إنجاح هذا العمل وتدعيمه وكذا جميع العمال الذين ساهموا باقتراحاتهم وإجاباتهم التي كشفت الغطاء على حقيقة التقييم هدفاً وطموحاً في التحسين.

أتقدم بشكري أيضاً إلى كل الأساتذة الكرام الذين ساهموا ولو بكلمة طيبة من أجل تشجيع هذا العمل بما فيهم العاملون والعاملات بدون استثناء.

هذا ولا أنسى أن أشكر عائلة مسلم على المساعدات القيمة وأخص بالذكر عائشة التي قاسمتني العناء والشقاء فكانت نعم الوفية.

وكذا أرف خالص شكري إلى الثلاثي على حسن الاستقبال وسعة خاطر الذين قاموا بطبع ونسخ هذا العمل.

وأختم شكري المبجل إلى كل من ساهم فيه من قريب أو من بعيد. لكم جميعاً كل شكري .

-بارك الله فيكم -

إهداء

قال لقمان لأبنيه ناصحاً :

" إن الدنيا بحر عريض، قد هلك فيه الأولون والآخرين، فإن استطعت فاجعل سفينتك تقوى الله
وعتقك التوكل على الله وزادك العمل الصالح، فإن نجوت فبرحمة الله وإن هلكت فبذنوبك... "

أهدي ثمرة جهدي للذي فطرني ومنّ عليّ بنعمه الجمّة وفضله العظيم الأحد الصمد، له
الحمد حمدا كثيرا ينبغي لجلال وجهه وعظيم سلطانه فله الحمد حتى يرضى، كما أهديه لسيد
هذه الأمة القائل : « طلب العلم فريضة على كل مسلم » محمد صلى الله عليه وسلم.
ثم أهدي هذا العمل إلى من قرنت طاعتها بطاعة ملك الملك وجل قوله فيهما:
« واخفض لهما جناح الذلّ من الرحمة وقل ربّ ارحمهما كما ربياني صغيراً »، أبي الذي
كان سببا في نتيجة هذا الجهد وأمي التي سعت تكليلا فيه.
أهدي هذا العمل إلى كل الإخوة والأخوات، الأهل والأقارب، الصديقات ، والزميلات
بدون استثناء وإلى طلبتي الأعزاء.
إلى كل طالب علم وإلى كل من أحبّ نعيمة في الله أهدي هذا العمل.

الفهرس

20	:	
20.....	:	
21.....	:	1
21	:	1
25	:	2
27	:	3
28	:	2
28	:	1
30	:	2
39	:	3
45	:	3
47	:	1
56	:	2
60	:	3
66.....	:	
68.....	:	
68.....	:	
69.....	:	1
70.....	:	1
73.....	:	2
76.....	:	3
88.....	:	2
90.....	:	1
96.....	:	2
110.....	:	3
120.....	:	3
121.....	:	1
129.....	:	2

133.....	:3
151.....	: 4
171.....	: 4
171.....	: 1
174.....	: 2
177.....	
179.....	:
179	
180	: 1
181	: 1
186.....	: 2
190.....	: 3
194	: 2
195	: 1
197	: 2
203.....(14000 9000)	: 3
211	: 3
211.....	: 1
213	: 2
215	: 3
218.....	: 4
221	: 4
222	: 1
226	: 2
	: 3
.240	
245	
247	:
247	:
248	: 1
248.....	: 1
250	: 2
252	:3

255	:2
255	: 1
258.....	: 2
259.....	: 3
264	: 3
265	: 1
279	: 2
281	:3
283	
285.....	

:

	Ô	
38		01
39		02
42		03
49		04
53		05
59		06
63		07
73		08
74		09
75		10
85		11
97		12
116		13
119		14
120		15
135		16
137		17
140		18
142		19
143		20
149		21
153		22
167		23
171		24
194		25
199	14000	26
205		27
224		28
225		29
235		30
242		31

252		32
253		33
265		34
266		35
266		36
267		37
270		38
272		39
274		40
275		41

	Ô	
78		01
79		02
80		03
82		04
104		05
130		06
154		07
216		08
239		09
255		10
262		11
262		12
268		13
269		14
271		15
276		16
278		17

المقدمة



...

() ()

...



Õ

"

"

3

3

.

3

3

"

Õ

"

"

"

3

.

...

3

3

.

3

3

3

.

..

-1

-

3

3

-



() (TQM)

-

-

-

-2

*

*

*

*

*



:

-3

3

.

3

*

3

3

3

3

.

*

Ö

3

3

3

3

3

3

3

.

*

.

*

.

:

-4

:

1





*

*

-

-6

-7

”الزبون هو المالك”



()

...

-8



Table with scattered characters and symbols (., :), and numerical values: 14000, 9000, and (14000 9000).



..

3

3

3

3

.

.

.

.

3

3

3

3

3

.

∴

(1)

∴

∴

∴

(2) ∴

"

" (H.M,Hamady)

∴

(3) ∴

∴

∴

∴

∴

(1)

/

=

(2)

.03 1998

(3)H.M Hamady, Administrative réform in developing countries with special reference to Egypte and lybia, PH.S this is University of strathclyde-Glasgow, 1975, P215-216.

:

:

: Ô .1

Õ

:

Õ

(1) "

" Ô

(Anne-RIBEROLLES) -

Õ

Õ

(2)"

-)

" :

(3)(

: (Gary Dessler)

: Ô .() "

Õ

(4)"

:

1

1

1

1

•
•
•
•

.3 (1)

(2) Anne RIBEROLLES, Evoluer vers un nouveau dialogue en ressources humaines, Edition achevé d'imprimer sur les presses de jouve, N° 1292, France, 1992, P13.

(3) opcit, P14.

		1	•
		1	•
		.	•
		Ö	
		(1)»	
	»	(Marie tresanini)	
	(2)»		
()	»	
		(3) »	
		:	
		»	
		(4) »	
		»	
		(5)»	

(1)

.19 2005

(2) Marie Tresanini, Evaluer les compétences, édition EMS Management & société colombelles, 2004- P 18.

.5 (3)

.01 2003 (4)

(5)

Ö : .2

Ö

ÖÖÖ

ÖÖÖ

ÖÖÖ

1

ÖÖÖ

ÖÖÖ

ÖÖÖ

ÖÖÖ

Ö :

2

5

1

42 1976

² .Dennis Molho, la performance globale de l'entreprise, édition d'organisation, Paris- France 2003 ; P 226.
 - Claude levy, évaluation du personnel : quels objectifs ? quelles méthodes ? éditions d'organisation Paris, 3^{ème} édition, France 2001, P 61.
 - Robert Bacal, Améliorer les performances de son équipe, maxima laurent du mesnil éditeur, France 2001, P.19.
 -Jacques Barraux, entreprises et performance globale, economica édition, Paris 97, P 64.
 - John R.Schermerhorn, Richard N.Osborn, Comportement humain et organisation, édition : village mondial, 2^{ème} édition, Canada 2000, P 252.



0

.1

0

000

000

0

0

1

.2

.3

0

0

-(

) -
0

.4

0

:

....

.7

.1



:

،

.5

: 1

0

0

0 000

000 0 000

000

000

000



1
 2
 3
 4
 5
 6
 7
 8
 9
 10
 11
 12
 13
 14
 15
 16
 17
 18
 19
 20
 21
 22
 23
 24
 25
 26
 27
 28
 29
 30
 31
 32
 33
 34
 35
 36
 37
 38
 39
 40
 41
 42
 43
 44
 45
 46
 47
 48
 49
 50
 51
 52
 53
 54
 55
 56
 57
 58
 59
 60
 61
 62
 63
 64
 65
 66
 67
 68
 69
 70
 71
 72
 73
 74
 75
 76
 77
 78
 79
 80
 81
 82
 83
 84
 85
 86
 87
 88
 89
 90
 91
 92
 93
 94
 95
 96
 97
 98
 99
 100

² Yves Emery , François Gonin, Dynamiser les ressources humaines, presses polytechniques et universitaires romandes, Paris 1999, P 14.

1
 : Õ
 ÕÕ Õ Õ Õ Õ
 Õ Õ Õ Õ Õ Õ
 Õ Õ Õ Õ Õ Õ
 Õ Õ Õ Õ Õ Õ
 Õ Õ Õ Õ Õ Õ
 Õ Õ Õ Õ Õ Õ
 Õ Õ Õ Õ Õ Õ

2
 Õ Õ Õ Õ Õ Õ
 Õ Õ Õ Õ Õ Õ
 Õ Õ Õ Õ Õ Õ
 Õ Õ Õ Õ Õ Õ
 Õ Õ Õ Õ Õ Õ
 Õ Õ Õ Õ Õ Õ
 Õ Õ Õ Õ Õ Õ
 Õ Õ Õ Õ Õ Õ

Õ Õ Õ
 :
 Õ Õ Õ Õ
 3"
 .327
 .328
 1
 2

Document téléchargé depuis www.pnst.cerist.dz CERIST

³- Anne RIBEROLLES, Opcit, P 19.

" : (Gary Dessler)

1"

" :

2"

" :

3"

" :

Ö

Ö

ÖÖÖ

Ö

Ö

4"

:

"

5" ...

ÖÖ

Ö

Ö

ÖÖ

Ö

Ö

Ö

.270

.53

.56

,2000

,21

.331

00

0000

:

0

.

.

.

.

.

1

:

00

²(Synergie)

00

00

00

00 00

00 00

00 00

00

00

00

00

00

00

.56-55

1

3=2+2 :

4=2+2 :

5 = 2+2

.²

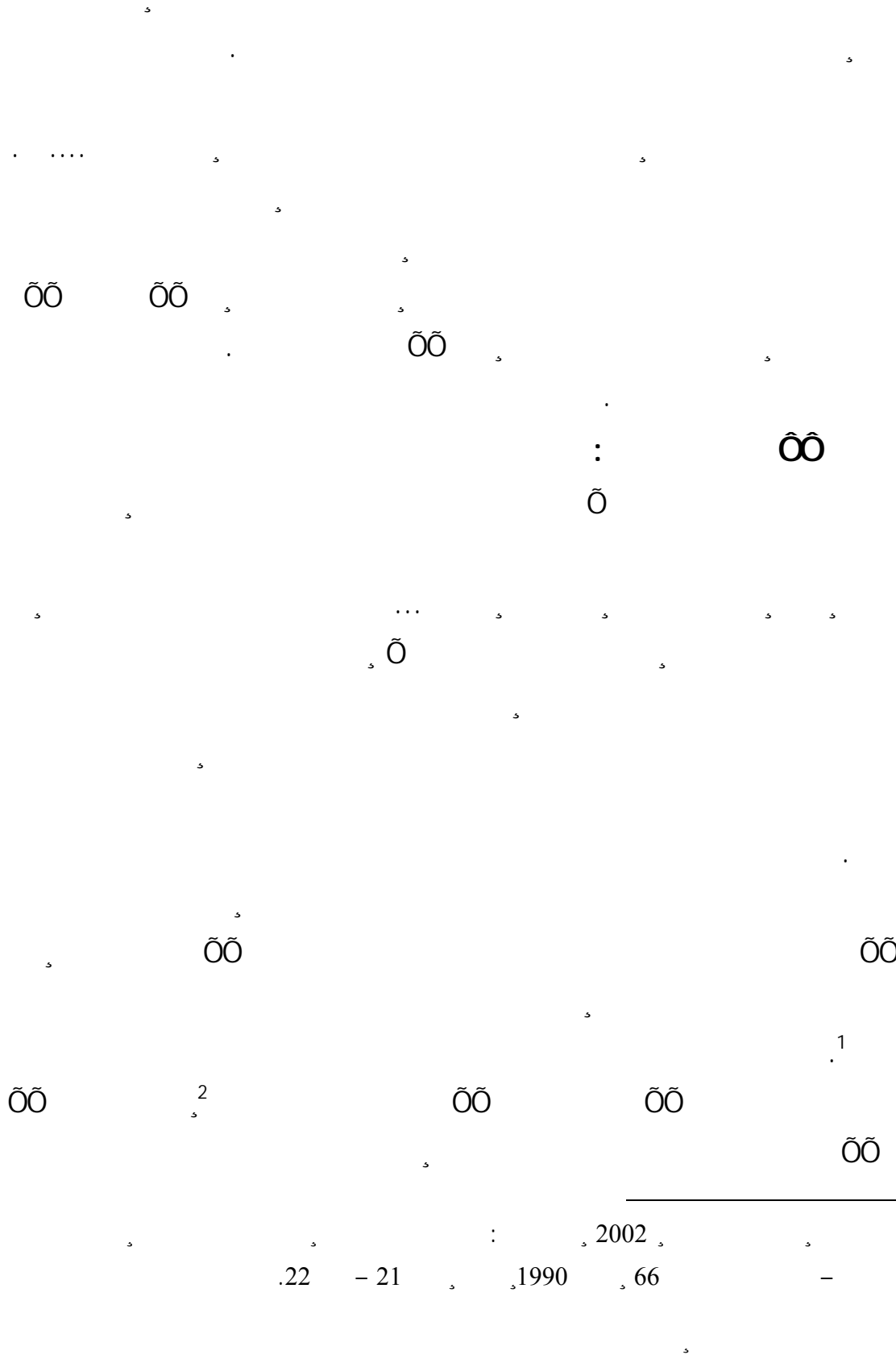

1

Õ

()

2

:

à

à

Õ

Õ

Õ

Õ

Õ

Õ

ÕÕ

ÕÕ

3

1

2

.73 2000

3

.100 2001

:

.1

.2

.3

õ

õõ

õõ

õõ

(-)

õ

õ

õ

õ

õõ

õõ

õõ

õõ

õõ

õõ

õõ

0

.

00

00

00

.

0

1

:

0

.

00

00

00

00

.

.2

:

0

0

3

:

.6

1

2

3

.5

.21

267

2000

310	2003				1
					316
					2
					*
					*
.65	1999			.272	1991
					*
					*
				.32	1995 6
2003					*
					.87

*Michel Darbelet, Laurent Izard, Michel Scaramuzga, Economie d'entreprise, collection tertiaire, édition : Foucher, Paris 1995, P 306.

1998

275,274,273

1

2

							1
							1
							-
						.330	,2000
							-
				.277.278	,2004		-
				Õ		Õ 248	,1999
,1998							-
						.235.231	,6
.386	,1991						-
,1997							-
							.258
.56	,1989						-
,1998	()			-
						.420	,2
.90	,1999			-	-		-

Alain vican, concevoir le système d'information de l'entreprise, les éditions d'organisation, paris- France. 1993, - P (121-129)
- Dunod, stratégie d'entreprise et communication, édition d'organisation, Paris 1992, P 09.

-1-

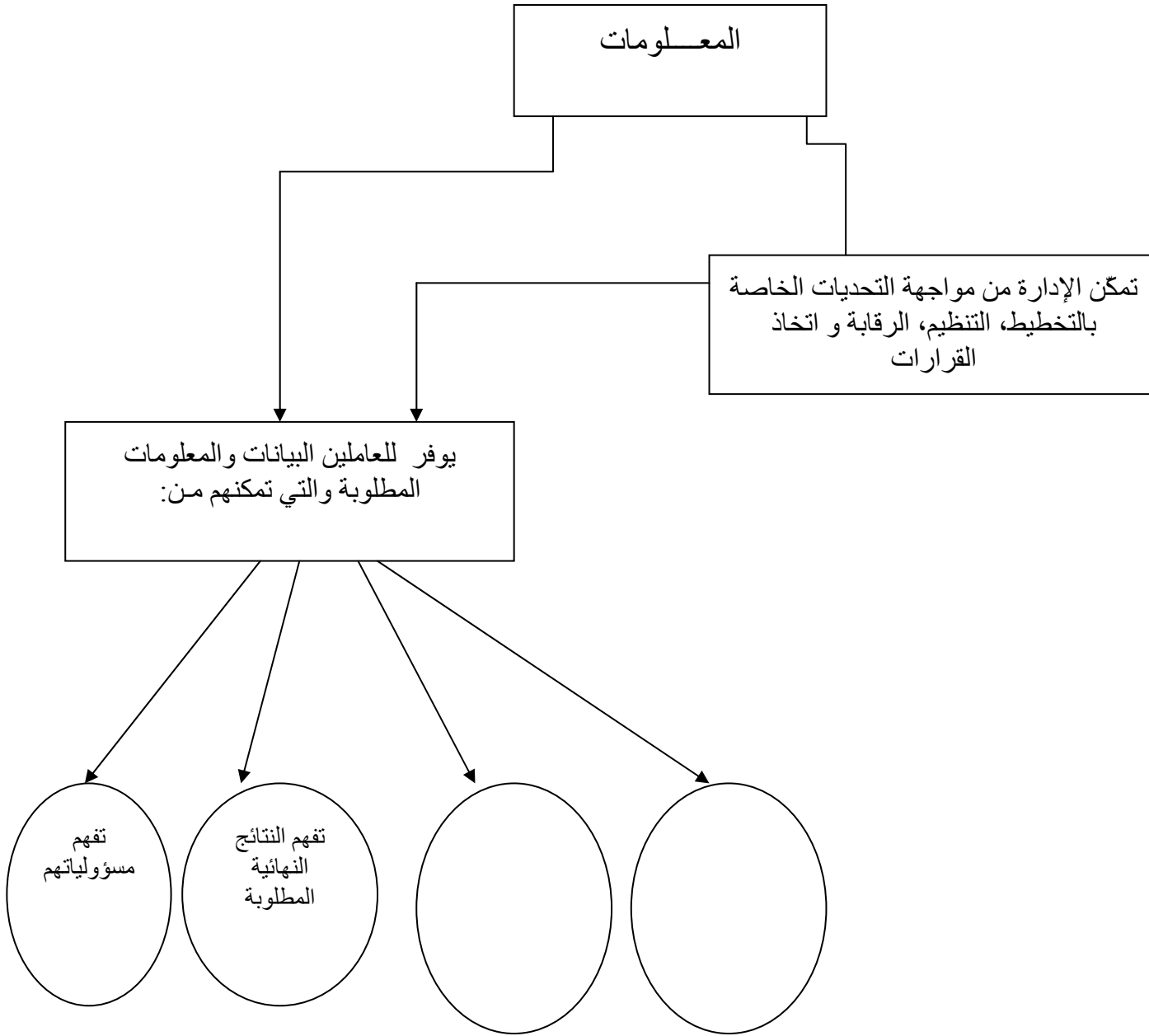

-2-

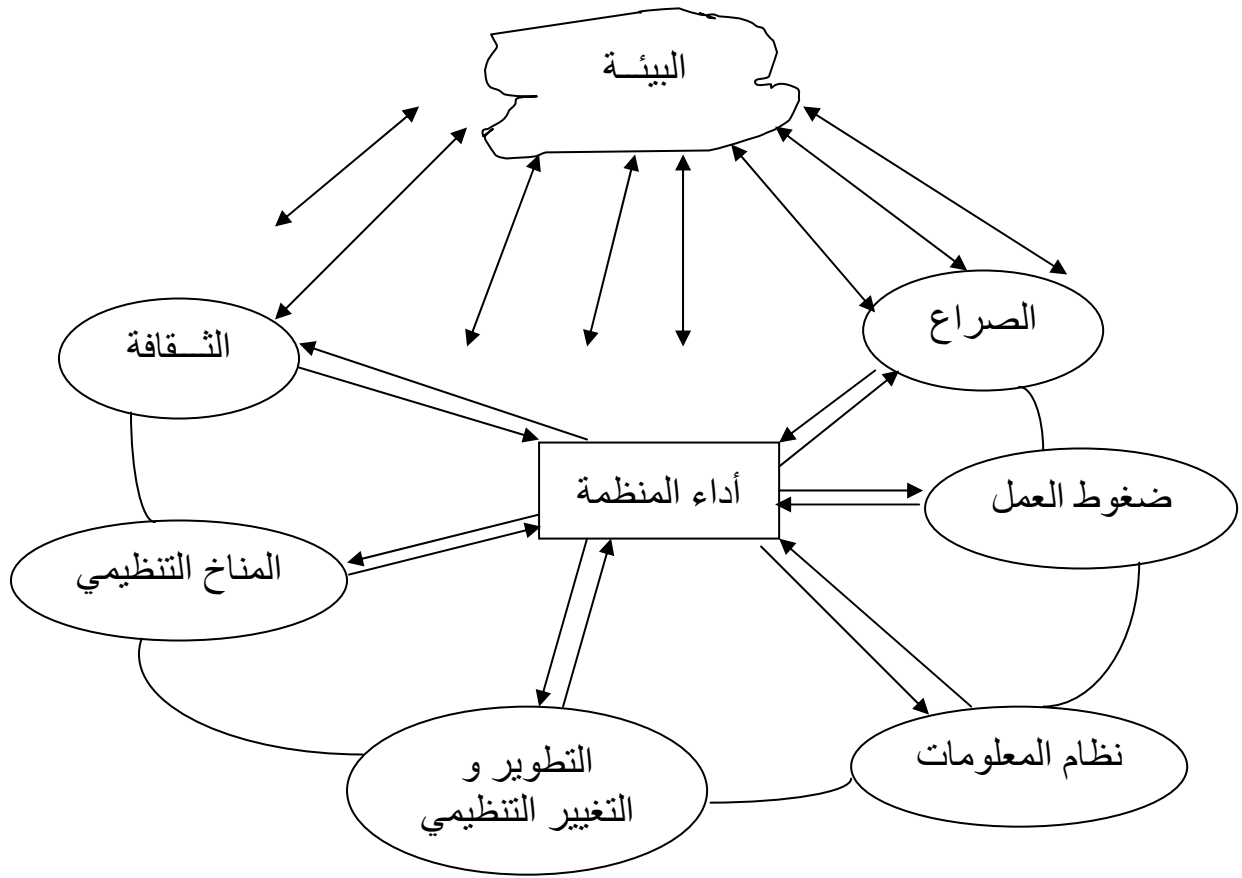

1

:

:

.1

00

00

0

00

00

00

:

.2

:

.3

00

00

00

00

00

00

00

00

00

00

00

00

00

00

00

00

00

00

00

00

:

.4

"

"

:

1

.02 1974

Ö

1

: Ö

ÖÖÖ

Ö

Ö .1
ÖÖÖ

Ö .2

0

Ö

Ö .3

2

1. شنوفي نور الدين ، مرجع سبق ذكره، ص 25،26.

2

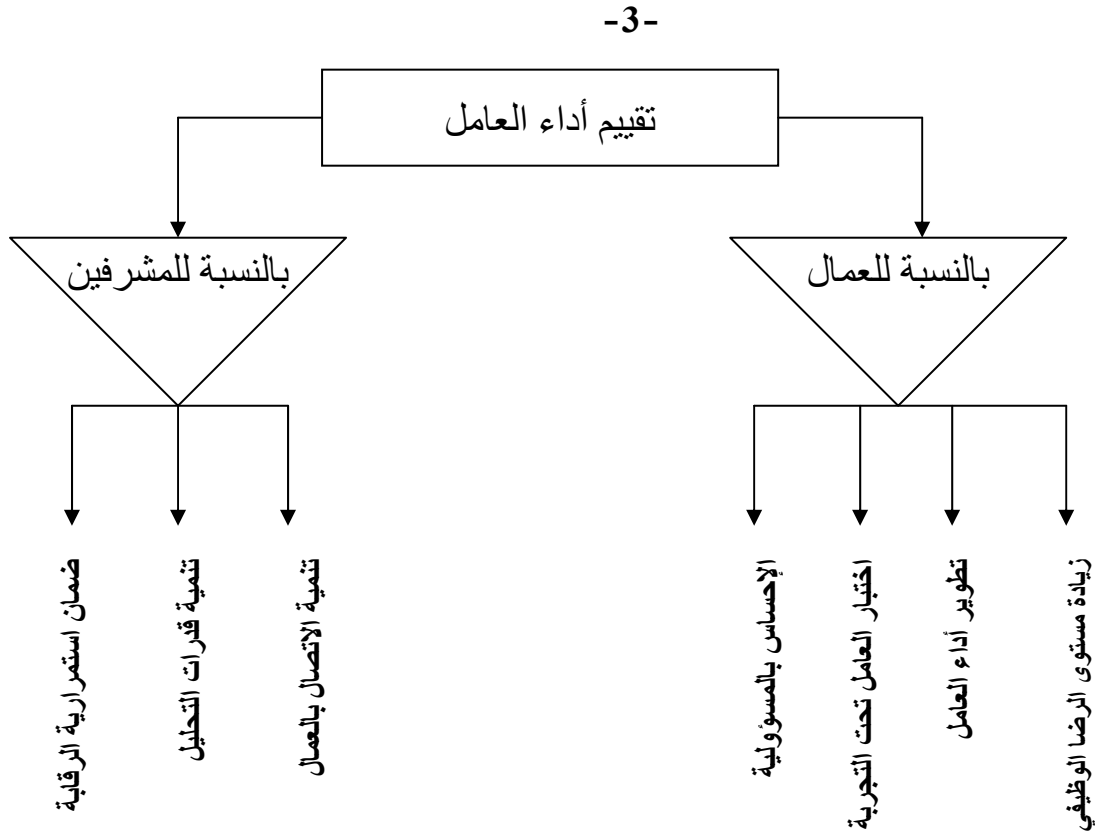

% 80

%90

Document téléchargé depuis www.pnst.cerist.dz CERIST

¹Henry carre, Diriger des salariés aujourd'hui, édition : maxima leurent du mesnil, Paris 1991, P 11,31,39,49.

:



.

:



1

-

1



1



1



1



1



1



1



س

س



1



س

.

1

Õ



Õ

ÕÕÕ

1

()



1



س

::

.

س

:

:

: (feed- back)

:1

:
1

1
1
1



.2

::

² Henry carre , opcit, P 55.

()

1

2

- 1

'' '' '' ''

.56,54

- 2



.487 486 2005

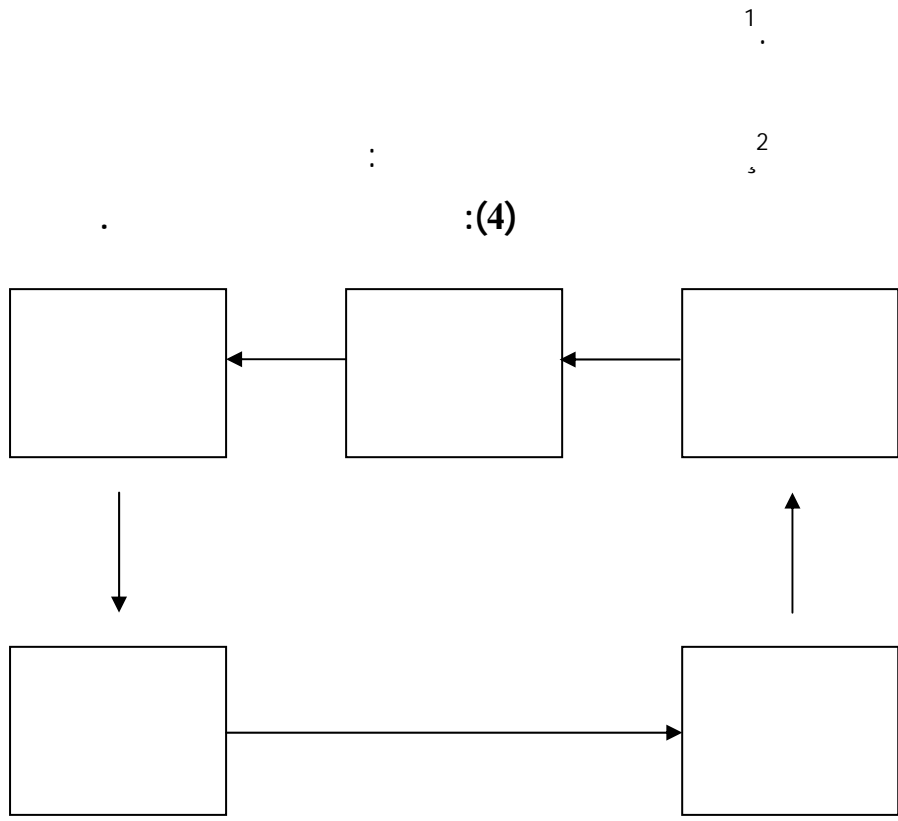

.283

:

1

1



:



¹(FCS)

(sous traitance)

:

1

•
•

()

1

1

•
•
•



1
1()

1

()

1

.1

1

.1
.2

-
-
-
-
-

:(5)

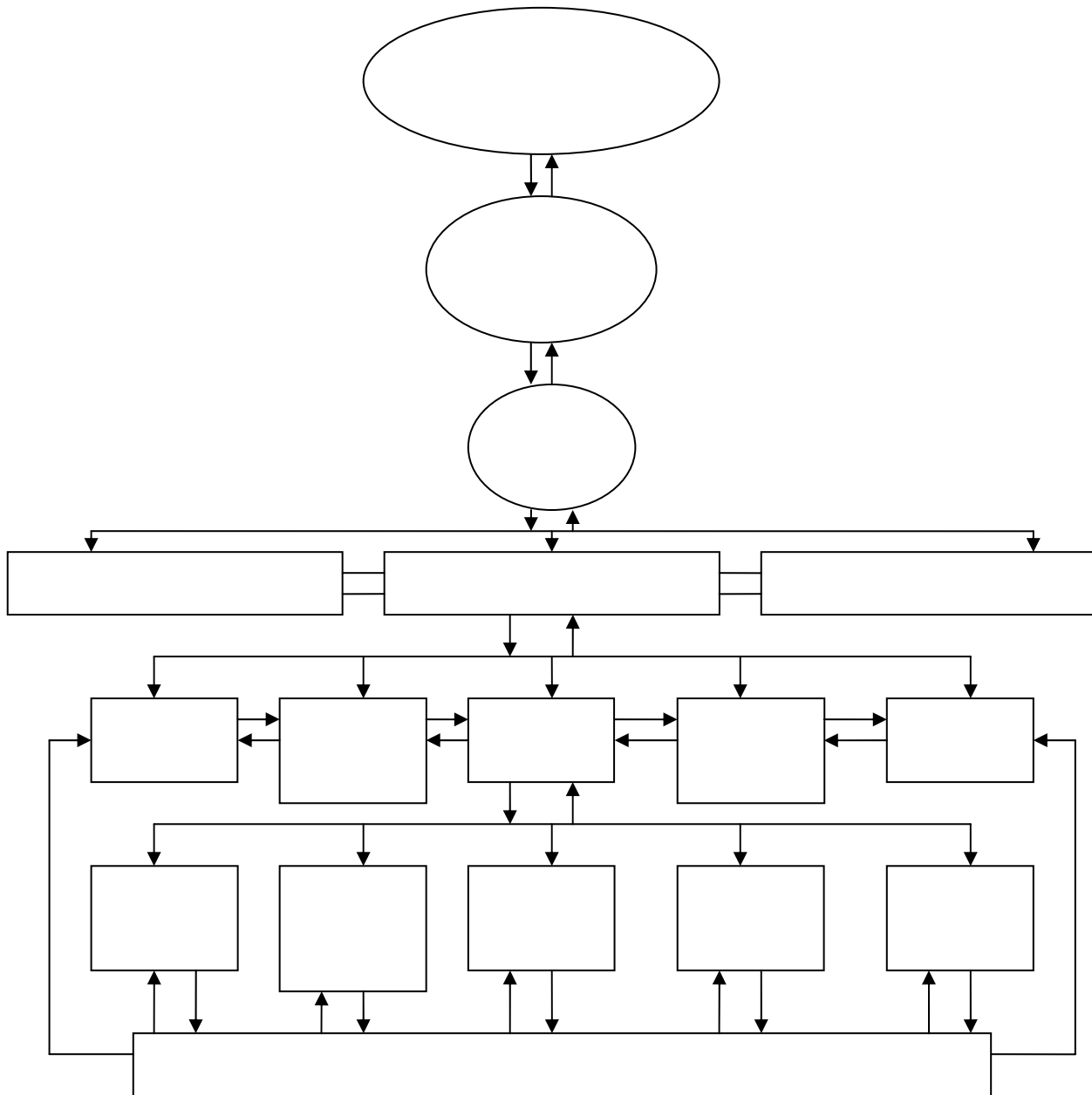

.77



⋮

⋮

⋮

⋮

⋮

1

1

⋮

⋮

1

⋮

⋮

1

⋮

⋮



•

•

•

-

(organisation structure)

(la structure)

.1

.2

.3

.4

1

1

1

()

1

:(6)

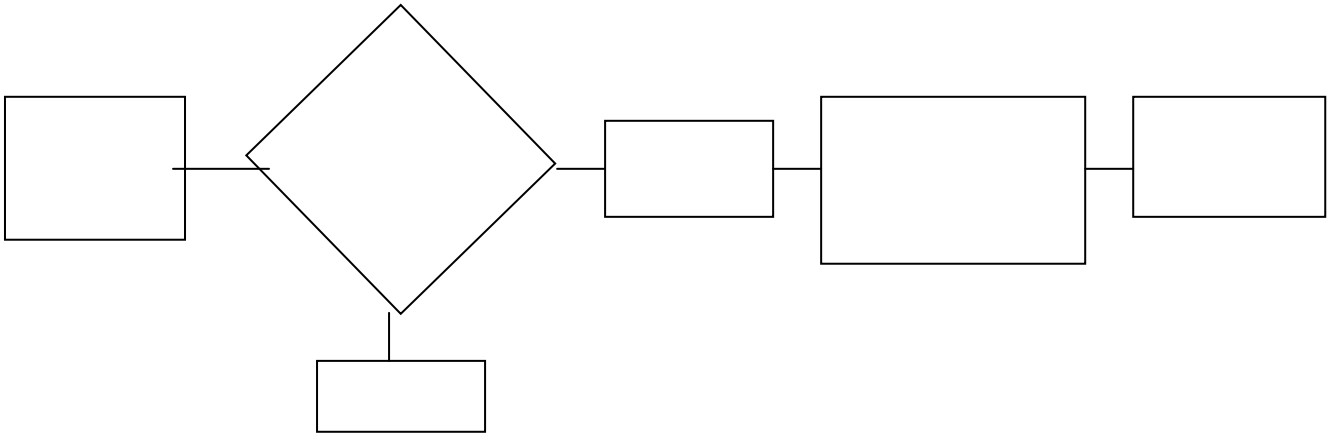

Thomar wheelen et david hunger, strategicale management sec,ed(N.yaddisn neiley publishing company)1986,p370.

1

:

1

:

2

.1

1

.

1

.

1

.

1

.

1

.

:

.

1

.

:

.

.13

_ 1

.16

_ 2





:

د

:

.

د

د

د

د

د

د

.

د

د

د

.

د

. . . .

د

د

.

:

.

د

د

د

.

د

:

.

د

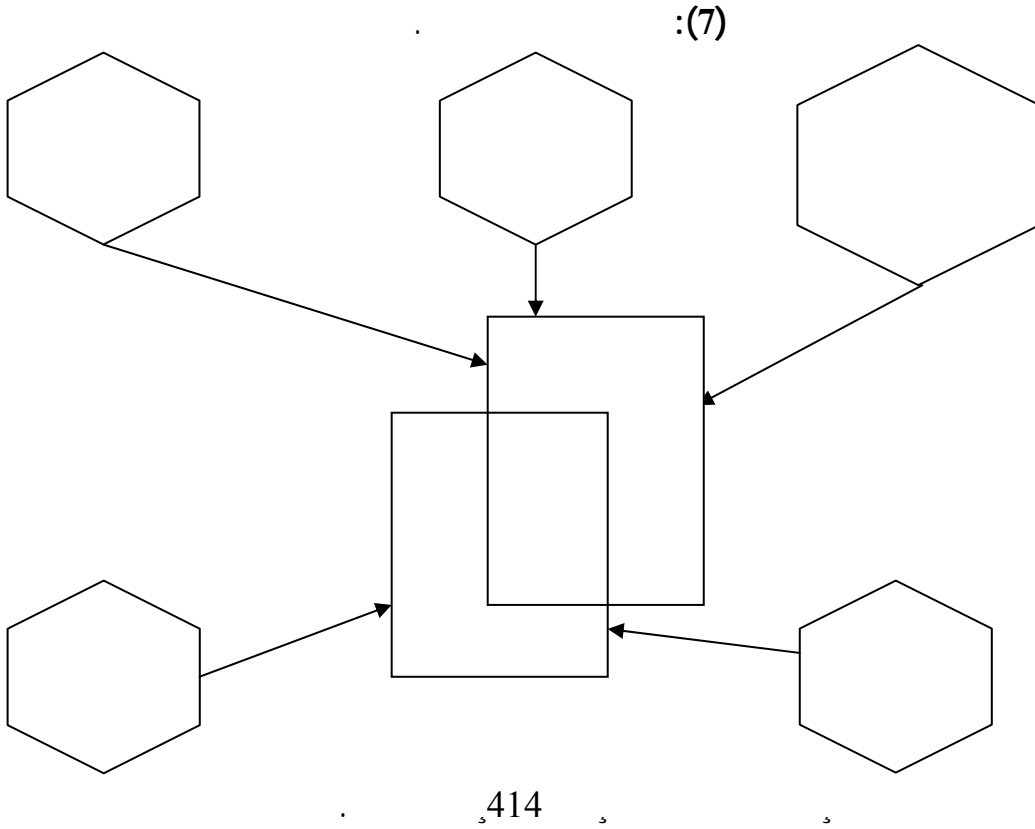

:(7)

414

:



..

1







⋮

⋮

⋮

⋮

⋮

⋮

⋮

⋮

⋮

⋮

1

⋮

⋮

⋮



⋮

⋮

⋮

⋮

⋮

⋮

⋮

⋮

⋮

⋮

⋮

⋮

⋮

()

⋮

⋮

⋮

⋮

⋮



:



:

()

س

:

س

•

س

1

س

•

1

1

•

1

•

1

•

س

1

•

س

س

1

•

س

1

⋮

()

1

1

1

:

1

1

1

1

.() ()

: - 1

:

:

.

1

.

1

()

.

1

.

:

.

.

.

1

.

.68

.36

- 1

-

- Aubin Nadia, évaluation j'ai la cote, édition:d'organisation, paris, France,2002,p206,p208.
- Pell arther, encadrer et motiver une équipe, édition:les échos, village mondiale, paris, france2001,p204.
- Katzenbach jon, douglas Smith, les équipes haute performance, édition: Dunod, paris, france1994,p136.

:



:

:

.1

:

:

•

1



:

:

•



1

•

1



:

:(08)

(2)	(20)	(1)
		...(19)
_____	-11	_____ -1
_____	-12	_____ -2
_____	-13	_____ -3
_____	-14	_____ -4
_____	-15	_____ -5
_____	-16	_____ -6
_____	-17	_____ -7
_____	-18	_____ -8
_____	-19	_____ -9
_____	-20	_____ -10

:()

.2

:



:(10)

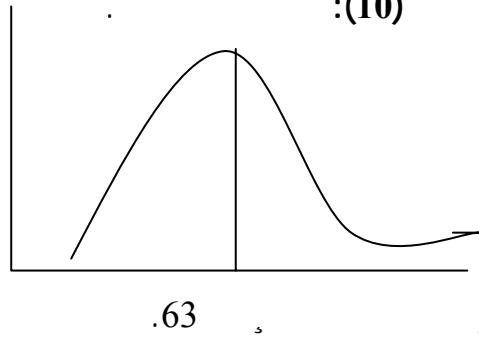

%10 Õ

%20

%20

%10 Õ

%40

1

1

1

(%10)



.4

:

''

3

5

-

2

1

2

3

16

''

2

3

4

5

3

3

4

24

''

3

2

5

4

2

5

3

24

''

''

:

1

()

3

3

1

1

.

1

:

''



1



:

3

¹-lapra jean – pascal, l'évaluation du personnel dans l'entreprise, édition Dunod, paris, 1993, p19.
-carre Henry, opcit, p40.
-Katzenbach Jon, smith Douglas, op.cit, p68.

:



1()



1 ()



:()

.1

.....	-1	
.....	-2	
.....	-1	
.....	-2	

:"1"

:



:

:(2)

			- - - - -

.141

س

س

:

.3

س

:

س

س

..

س

:

1



.

:



س

س

1



س

1

.

.

- 1-Aubert Nicole,Hoffmann Hervé Michael, diriger et motiver; édition d'organisation, paris, 2000, p225.
- Vern Christine, l'évaluation des compétences, édition liaisons, paris, 2002, p33.
- malho denis, fernandez-poisson, op.cit, p188.
- Emery Yves, Gonin francois, op.cit, p67.

:

:(3)

.....						-	1
.....	o					-	2
.....						-	3
.....					o	-	4
.....					o	-	5
.....					o	-	6
.....	o					-	7
.....		o				-	8
.....					o	-	9
.../...										

.
:
: .4

1
s

2
s

:



1



1



1



1

-1

-2

:



1

1992

"

"

(Harvard Business Review)

(les facteurs clés de succès:FCS)

2

1[

]

•

. [

]

•

207

2004

.109

- 1

- 2

:

.1

o

:

...o

o

.2

1

.3

1

.4

o

:

:

1

.

.

1

.

1

☞

☞

☞

1

.

:

:

1

:

:

:(04)

	*	*	
	*	*	
	*	*	
*	*	*	
*	*	*	

:

	*	*	*	*
	*	*	*	*

.106 2003

:

3

3

3

1

,

:

1



1



1



1



1



2



:

.

:

1

.

1

.

.

1

.

3

1

.103

- 1

228

- 2

:



1

د

1

د

1¹

د

د

1

د

]

د

د

د

1²

:

د

د

:

د

د

د

1

د [...

د

د

:

:

د

244

110

- 1

- 2

:(11)

.1

<p>.....</p> <p>.....</p> <p>.....</p> <p>.....</p> <p>.....</p>	<p>.....</p> <p>.....</p> <p>.....</p> <p>.....</p> <p>.....</p>
--	--

.2

[]:()

			/
			-
			-
20/1	20		-
			/

(1)

$$\frac{4 + 3 + 2 + 1}{4} = 1$$

:

:

.

	"						
		5	4	3	2	1	
							: -1 -2 -3 -4 -5
							: -1 -2 -3 -4 -5
							: -1 -2 -3 -4 -5
Σ	Σ						

:

(2)

= 2

:

.

	"						
		5	4	3	2	1	
							: -1 -2 -3 -4 -5
Σ	Σ						: :

:



: (3)

$$\underline{\hspace{10em}} = 3$$

:()

	3	2	1	
%100	0.10	0.30	0.60	
20/	0.10×3	0.30×2	0.60×1	

: ()

$$(0.10 \times 3) + (0.30 \times 2) + (0.60 \times 1) =$$

: .3

-	-	
-	-	
-	-	
-	-	
.....:		

.....:	-
.....:	-
.....:	-

: .4

.....:	
.....	
.....	
o	-
.....o	-
o	-
.....o	-
.....:	
.....	
.....	

:



:

.5

.....:

:
.....:
.....:
.....:

():
.....
.....
.....

():
..... -
..... -
..... -

.....:

.247,252

,

,

:

:

.1



⋮

⋮

⋮

⋮

⋮

⋮

⋮

⋮

⋮

⋮

⋮

⋮

⋮

⋮

⋮

⋮

⋮

⋮

⋮

⋮

⋮

⋮

⋮

⋮

⋮

⋮

⋮

⋮

⋮

⋮

⋮

⋮ 53

⋮ 2001

⋮ 1



⋮

1

(Développement des ressources humaines:DRH)

:



1

(/ / /)

2

3

:(Efficiency)

.16 2001

.382

.17

- 1
- 2
- 3

:



3

3

3

3



(Katz et Kahn)

:

(Efficacité)

3

3

3

3

(Kast et All)

3

3

3

(Mahoney et Steern)

3

3

3

3

(Yuchtman and Seasher and Etzioni)

3

3

3

3

3

3

3

0

3



()

1

6

-1

-2

-3

-1



:



1

)

(

2

...

.332

4

- 1

383

- 2

:

:

1

:

-1

:

-1

:

-2

:

-3

:

-1

Malé

:

•

•

•

•

Richman et Farmer

- aubin Nadia,opcit, p225.
-henri jacot jacques, troussier jean francois, travail, compétition performance, édition economica, paris, 1992, p171.

:



:

-2

Morley

Mahney

H.Simon

:

-3

()

:

:(12)

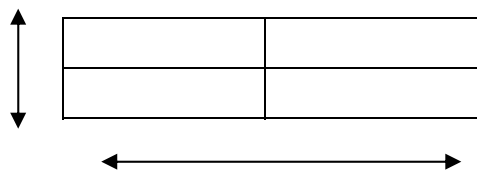

:

Malé

:

$$\underline{\hspace{2cm}} = \underline{\hspace{10cm}} = \underline{\hspace{2cm}} =$$

:

$$+ =$$

$$+ =$$

3

3

" "

" "

3

3

1

:

•

:

(

:

$$\underline{\hspace{10cm}}$$

:

-1

.13 9



3

1



1



:

3

.

3

3

.

3

3

3

3

3

3

3

.

-



.

0

3

0

.

3

3

3



() _____ =

:

:

-

3

:

-

3

3

3

.

☞
☞
☞
☞
☞
☞

☞
☞
☞

☞
☞
☞

☞
☞
☞

☞
☞
☞

(

)

•

•

•

☞

☞

☞

☞

☞

:

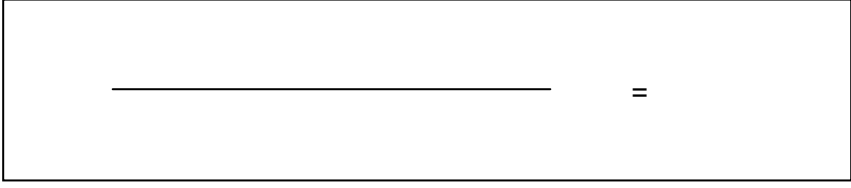

Alan Lawlor



:



:

. ()



." "



:

.1

o

o

o

:"

"

.2

o

o

:

(

o

o

o

:

-1

-2

-3

-4

-5

-6

-7



د د د

د د

د د د

د د

.

د

:

/

1

د

د

.

د

د

1

2

:

.

د

د

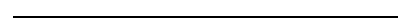

:

-1

.17

د

د

.38 31

د

د

-2



<p style="text-align: center;">-2</p> <p style="text-align: center;">-</p>	<p style="text-align: center;">*</p> <p style="text-align: center;">=</p> <p style="text-align: center;">100x</p>	<p style="text-align: center;">*</p>
<p style="text-align: center;">-3</p> <p style="text-align: center;">,</p> <p style="text-align: center;">;</p>	<p style="text-align: center;">*</p> <p style="text-align: center;">-</p> <p style="text-align: center;">100x</p>	<p style="text-align: center;">*</p> <p style="text-align: center;">.</p> <p style="text-align: center;">,</p>

		.H
	<p style="text-align: center;">-3</p>	<p style="text-align: center;">-4</p>
	<p style="text-align: center;">100×</p> <p style="text-align: center;">;</p> <p style="text-align: center;">100×</p> <p style="text-align: center;">;</p> <p style="text-align: center;">100×</p>	<p style="text-align: center;">;</p> <p style="text-align: center;">;</p> <p style="text-align: center;">;</p> <p style="text-align: center;">;</p> <p style="text-align: center;">;</p>
	<p style="text-align: center;">*</p>	<p style="text-align: center;">*</p>
		<p style="text-align: center;">Document téléchargé depuis www.pnst.cerist.dz CERIST</p>

<p> $\frac{1}{100 \times}$ $\frac{1}{100 \times}$ $(\quad)^2$ </p>	<p> $\frac{1}{100 \times}$ $\frac{1}{100 \times}$ $(\quad)^2$ </p>	<p> $\frac{1}{100 \times}$ $\frac{1}{100 \times}$ $(\quad)^2$ </p>	<p> II </p>
	<p> $\frac{1}{100 \times}$ $\frac{1}{100 \times}$ </p>	<p> $\frac{1}{100 \times}$ $\frac{1}{100 \times}$ </p>	<p> III </p>

æ	=	*	-1
			:
	100x	*	- 2
			:
n100	:	*	-3
	100x	=)
			(

III

: |

..



"

"

د

د

د

د

.

د

Porter

د

د

د

:

د

,

X

||

د

د

.

د

...

د

د

د

⋮



⋮

1

.

⋮

⋮

⋮

⋮

⋮

:

+

+

+

=

2

.

+

+

+

()

()

.2002/2001

⋮

⋮

.23 1988



- 1

- 2

⋮

⋮

:



(Super)

1

(Herbert)

:

1

-

2

:

.1

☞

-

.24 -1



⋮

⋮

⋮

⋮

⋮

⋮

⋮

⋮

⋮

⋮

⋮

⋮

⋮

⋮

⋮

⋮

⋮

⋮

⋮

.4

⋮

1

⋮

⋮

.5

⋮

⋮

.6

⋮

⋮

⋮

0

0

⋮

_ 1



:

.7

:

3

3

3

1

:

3

3

3

:

3

:

3

3

3

.

3

3

:

3

3

2

:

3

3

3

3

3

:

1

1



.231

_1

.234

_2

³ ROUSSEL Patrice, opcit, p228

:



: .1

(Shows Blum)

(Sheriadam and Slocum)

(Herzberg)

33

%2

1

(Vroom)

•

•

(Katzel, barrett, and Parker) (Katzel, Kendell, Hulin)

:

...

•

•

•

•

:

0



د

د

د

د

د

د

د

د

د

د

د

"Z

"

.2

:

د

.

د

:(13)

الاحتياج من عدمه لعدالة

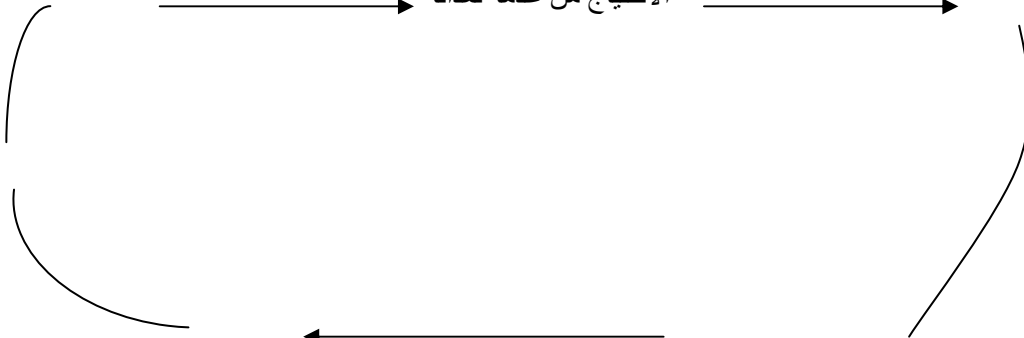

12

()

:

" "

د

:

Porter

(Green)

(Bowen and Siegel)

•

Porter and Lawlar

•

Porter and Lawlar

•

:

-1

-2

()

:

•

•

•

.3

:



(Wanow)

:



(Backman)

(Greene)

:

-1

-2

:

()

()

) (...)

.1(

:

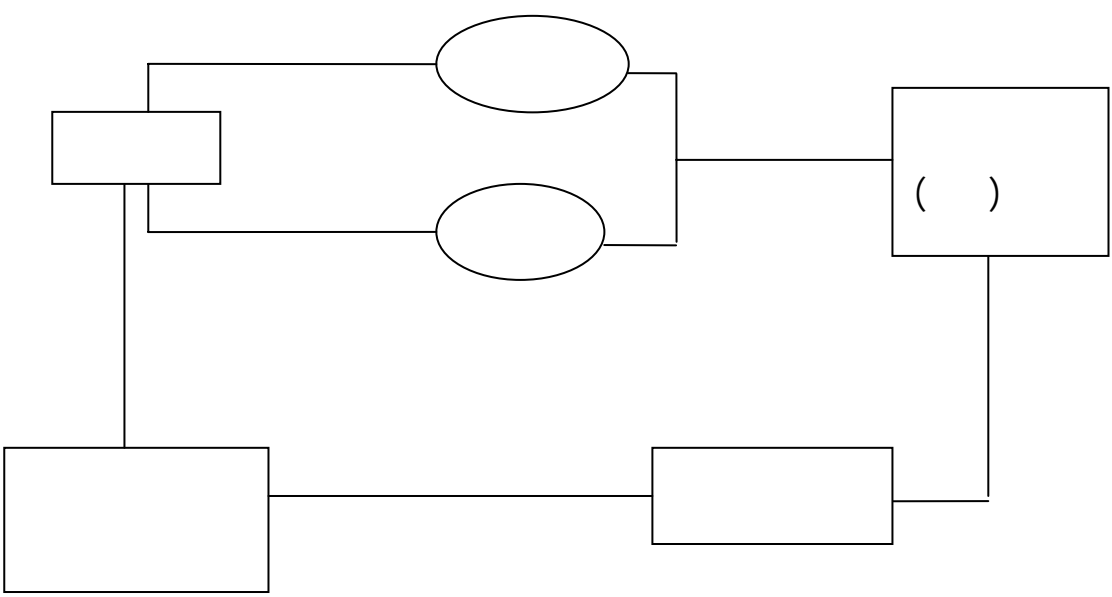

:(14)

:

:(15)

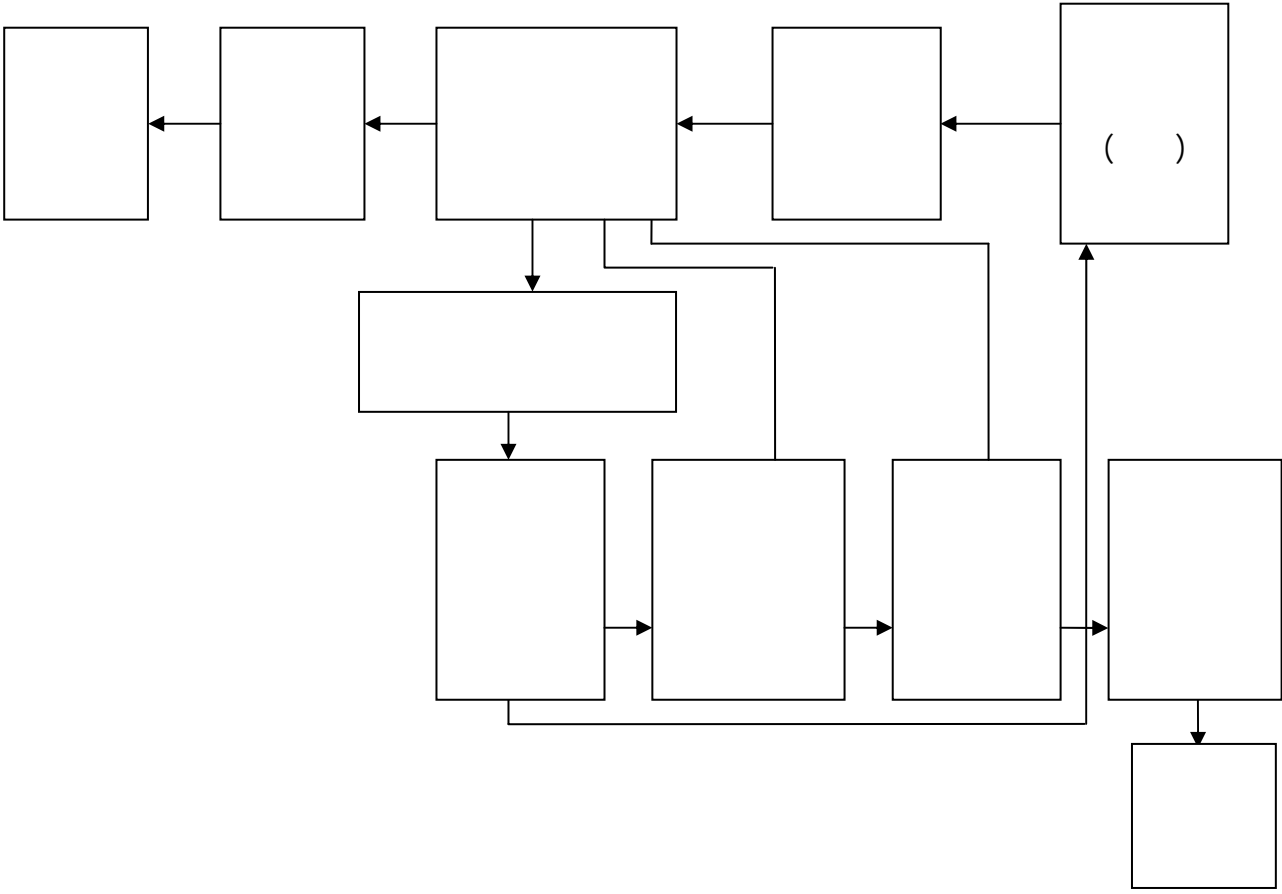

.35

:

.1

1

.2

.1

:

.36

- 1



1"

"

" (Mc Gregor)

2"

3

¹ - Roussel Patrice, opcit, p 146.

-Christine Vern, opcit, p77.
 -Denis Malho, opcit, p188.
 - Riberolles Anne, opcit, p69.

.134 1997

.151

.433

.335



:

:

-1

3

3

3

-2

3

.

-3

3

3

3

1

-4

3

3

:

:

.

:

.1

3

:

3



1

1



1



.

:



:

.2

.

:

1

*
*
*
*
*
*
*

.

:

.3

.

.

.

.

.

:

.

.

.

.

.

•
•
•
•
•



..

..

*
*
*
*
*
*
*
*

.4

*
*
*
*
*
*
*
*
*
*



1

*
*
*
*



.5

1

1



:



1

..

(MARTINDELLE)

"

2 (...)

" (Leonard)

3"

()

² Patrice Roussel, opcit, p 135. -

.99 -¹

.435 -³

.336 ,335 -

:



:

:(06)

) (
			-1
			-2
			-3
			-4
			-5
			-6
			-7
	/		-8
			-9
			-10
			-11
			-12
		()	-13
			-14
			-15
			-16
			-17
			-18
			-19

1

1

:

1

:

.1

.2

.3

.4

)

(

)

.5

.(

.6

.7



:



:

:

:

1

-1

-2

-3

-4

-5

:

-1

-2

-3

-4

-5

-6

:

:

:

-1

-2

-3

-4

-5

:

-1

...

3

3

3

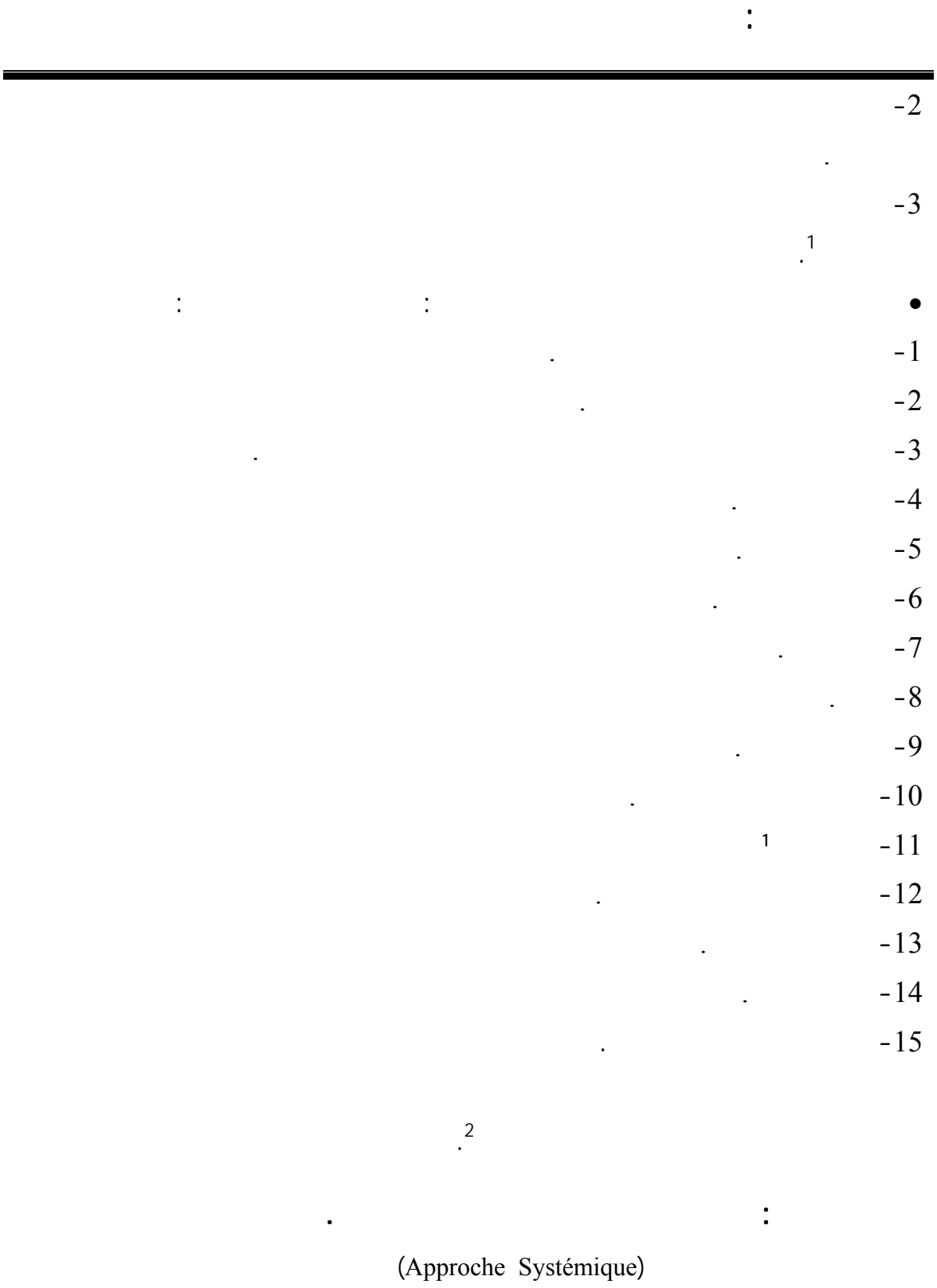

¹ -Roussel Patrice, opcit, p138
 .44 ,2001 ,

:

Ludvic Von)

1

(Bertallanffy



2

.(Variété)

()

)

.(

(

...

o

o

:

)

()

...

:

(Variety)

(Feed Back Control)

(Regulator)

(Regulator System)

:(16)

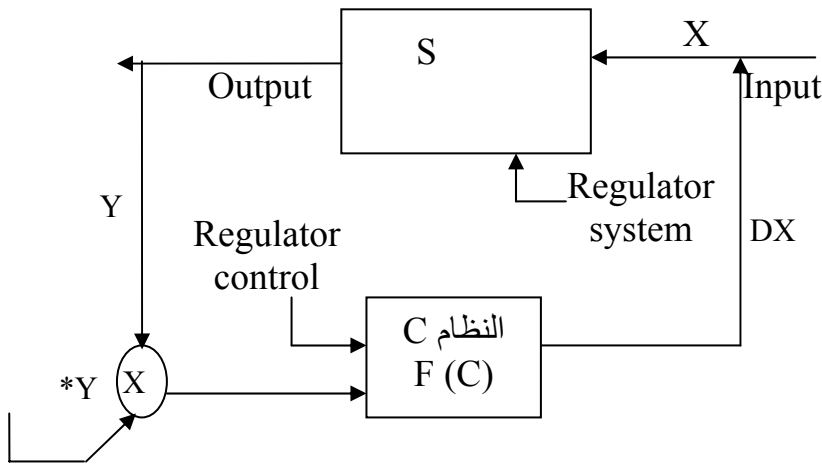

.2

Y^*

(S)

C

Y

X S

(D)

(Katz+Kahri)

()

-1

-2

-3

-4

.(

-5

feed)

(Regulator)

(back

¹(Paradigme)

:

:(17)

Radical Humanism	Radical Structuralism
Interpretive	Functionalist

.13 , :

:¹Hard Systems Thinking(H.S.T): .1

(Bell telephorie)

(Hall)

.()

System engenering (SE) -1

System Analyses (SA) -2

Operational Research (OR) -3

() :

:

1

(Simulation)

:

()

1

:

()

:

Rand Corporation

RMC Normara

: - 1

-H.Miser+ E.S Qualle, Hand Book of Systems Analyses: overview of uses, applications, procedures and pratice, North, Holland,1985.

- H.Miser+ E.S Qualle, Hand Book of Systems Analyses:Grqft Issues and procedural chores, J.Wily,1988(N4).

:

1965

Institute of Applied System Analysis ()

1972

:

1 *

1 *

1 *

1 *

1() *

1 *

:

:

1 *

1 *

1 *

1 *

1 *

1 *

:Ö

W.Churchman, Ackoff, Arnoff, Sutroduction to operations research, J.Wiley, 1957.

Ackoff

:

:

1!

o

-1

-2

check

1land

	:		
<hr/>			
	o	:	-3
1			
			-4
			1
	1		-5
			-6
1			
:	:Soft Systems Thinking(S.S.T):	.	.2
		1	-1
		1	-2
		.	-3
:			

:

:(18)

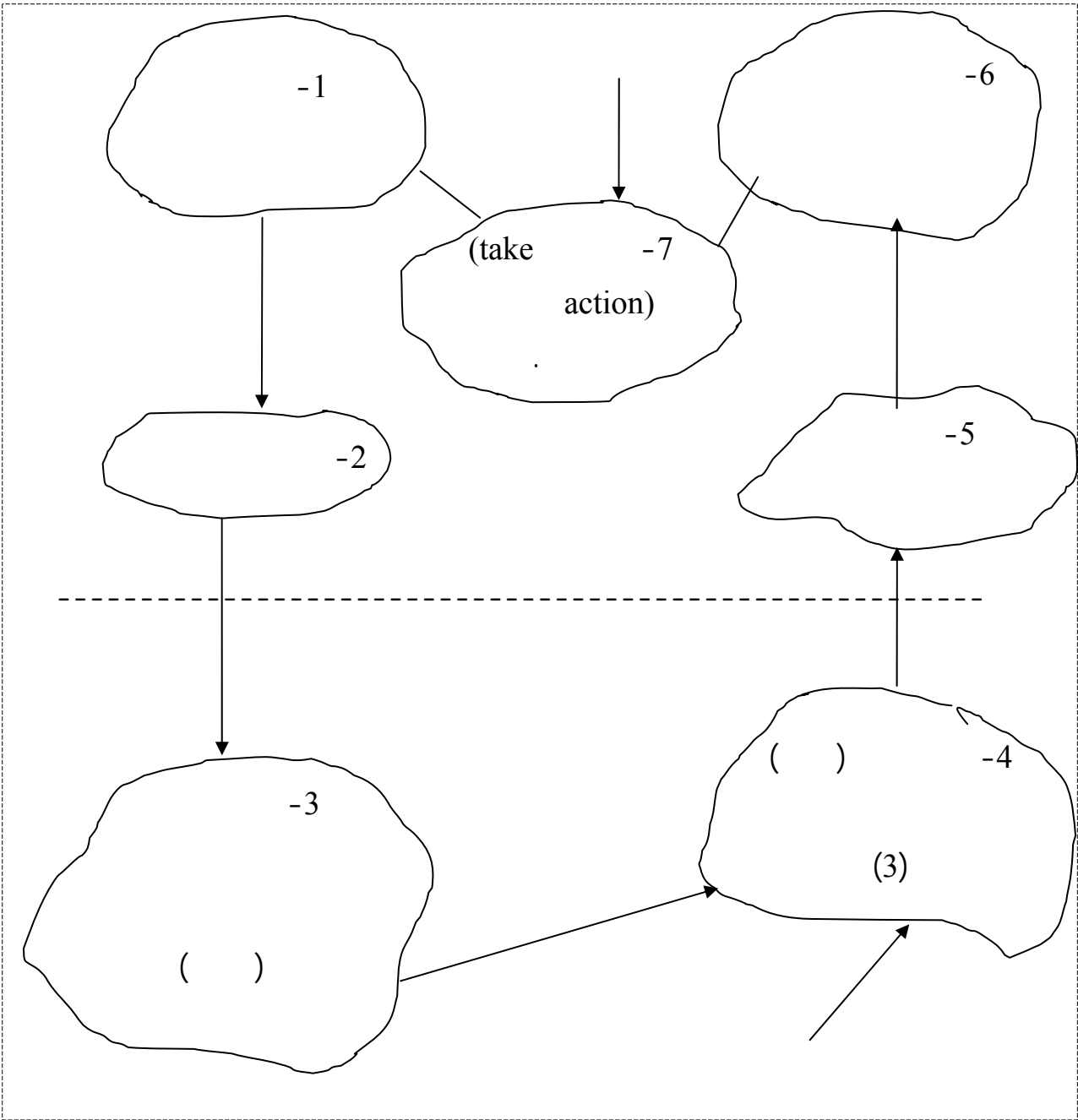

.14

(7)

(learning process)

:



:

.

(Régulateur)

-1

1

-2

1

1

-3

-4

1

-5

1

-6

1

-7

.

S.S.M

.

.

.

: (The Cybernétique Model)

.3

.

.

.

.

.

.

:

Viable

V.S.M:

¹Systems Model

:

:

:

-1

(Dimension Réursive)

-(Focus)

()

()

A.B.C

Dimension Réursive

A.B.C

:(19)

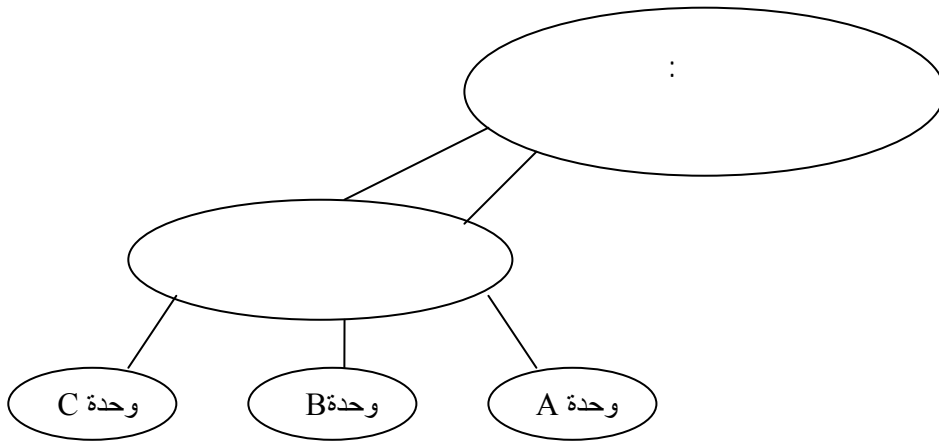

: viable⁻¹

Stafford Beer

-2

(Opérationnel Elements)

(Management Unit:MU)

(Complexity)

(Variety)

:(20)

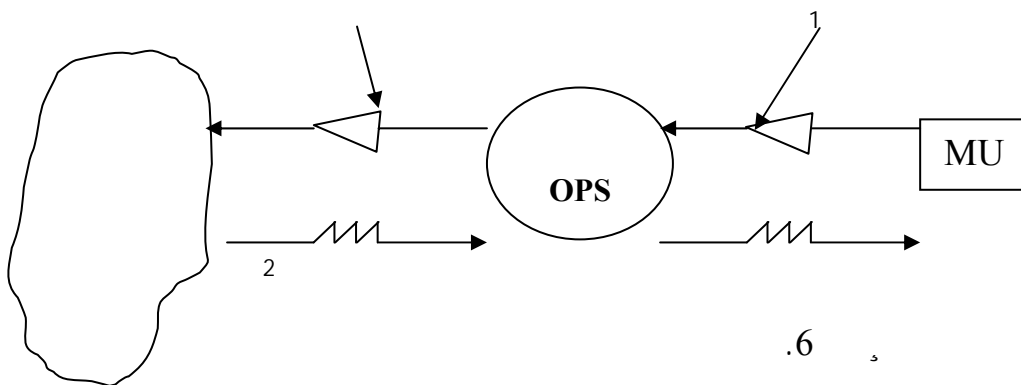

:

.Ashby

:

V(ENV)>V(OPS)>V(MU) : Ashby

.(S1) (System 1)
(VS)

.()

Meta System:

.(OES)

(Meta System)

.(System-in- focus)

(VS)

.(S1)

:

:

-3

(VS)

)

(

:

(2 OE)

(S1)

(Meta System)

(Meta System)

(S1)

()

(S1)

()

System2 2

(Meta System)

(Regulatory Centre)

(S2)

(VS)

(OE)

(S2) 2

(S2)

:

:

-4

(S1)

(Meta System)

(Meta System)

(

)(S1)

o

) (Variety)

(

Meta)

(S1)

(Variety)

(System

(Meta System)

(S2)

(S3M)

:

(S1)

(Variety)

(Meta System)

(S2) (s1)

(S3)(System3) 3

(VS)

(S3M)

(S2)

:

:

-5

o

(S3)

(VS)

()

()

()

(S1)

:

:



.()

()

.....

:(S4)

.(X)

RD-

1

X,Y,Z,

1

.X, Y, Z

(S1,S2,S3)

.(VS)

.(S4)

(S4)

(S3)

.....

o

(Variety)

)

(S4)

(S4 (S3)←(S1)

..((S3)←(S4)

:(S3)←(S4) :

-6

(S4) (S3)

(S4)

(S3)

(VS)

:

(Meta System)

(Variety)

(S3) ↔ (S4)

(S5)

(S3) ↔ (S4)

(S5)

(Meta System)

(S5)

(Ashby)

1"

(S5)

(S4) (S3)

(VSM)

(S5)

(S4) (S3)

...(S6)

(S5)

:

:(21)

.(VSM)

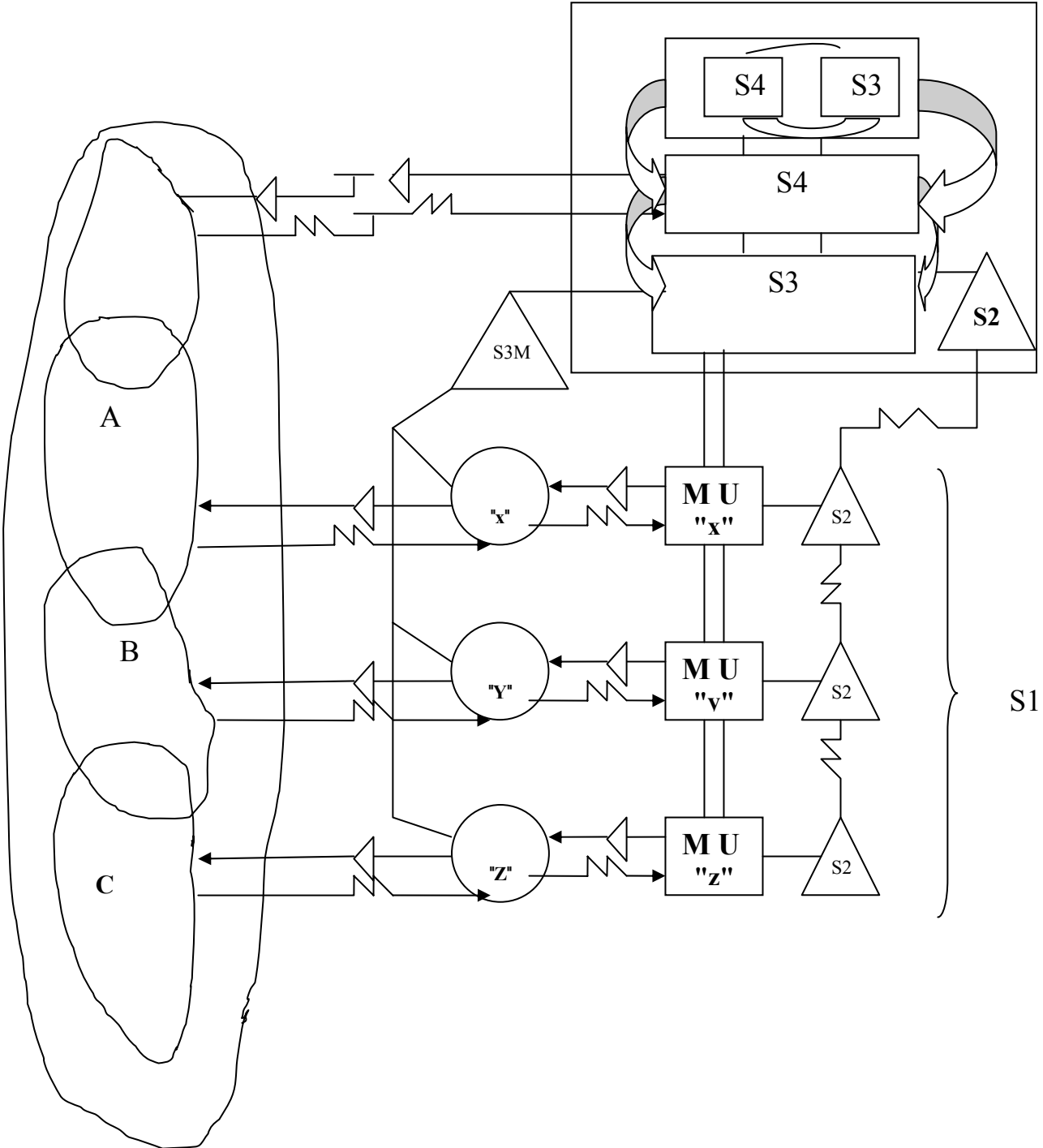

S1

:

⋮



(VSM)

0

•
-1
-2
-3
-4
-5



⋮



1

2

.29

-Roussel Patrice,, opcit, p140.

- IDEM P142.

- Jean- Paseal Lapra, Opcit, P85.

- 1

-

- 2

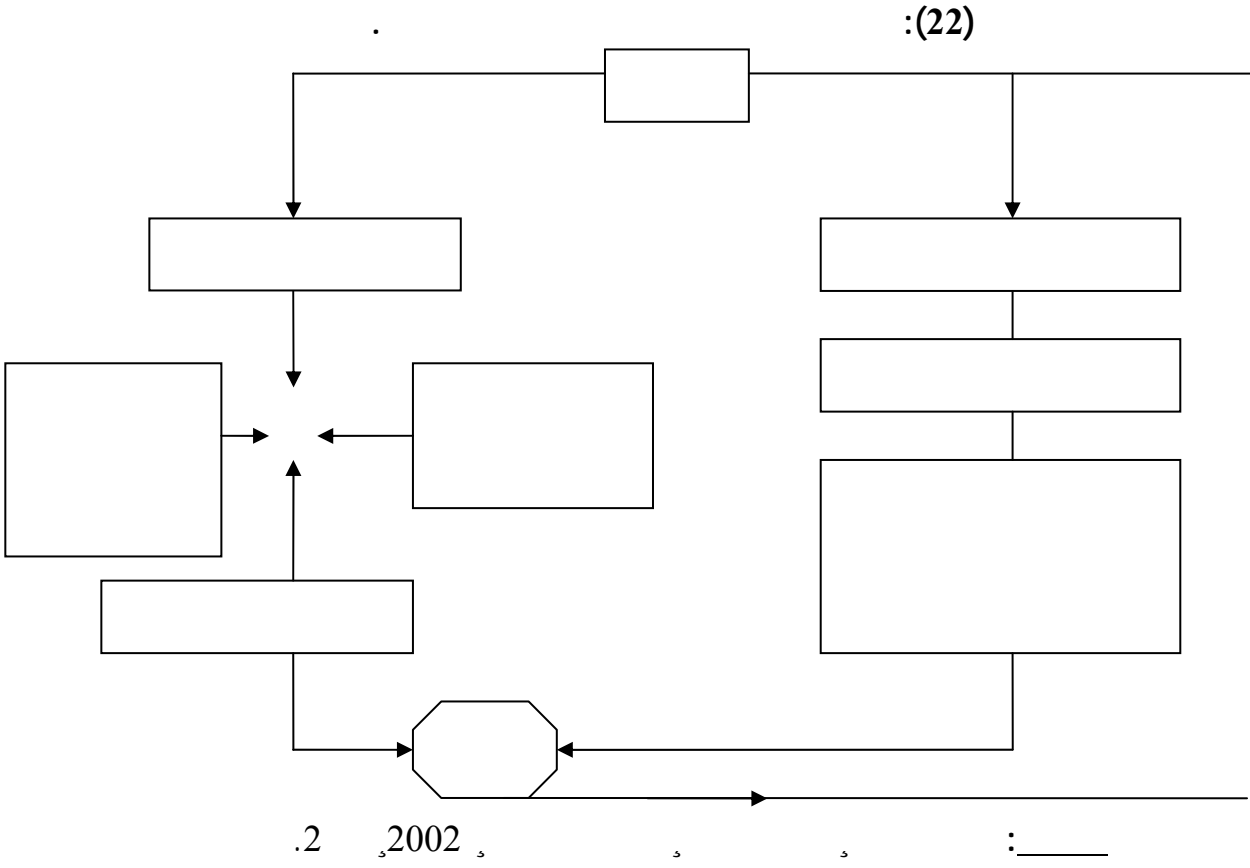

:

:(7)

()	

.3

:

-()

¹- Henry Carre, opcit, p67 .



:

:

.2

1

2

3

:

.

:

4

-1

-2

-3

¹- Claude Lévy- Leboyer, opcit, p113.

²- Patrice Roussel, opcit, p61.

³-Pell Arthur, opcit, p 167.

1

2

3

4

5

6

7

8

9

10

11

12

13

14

15

16

17

18

19

20

21

22

23

24

25

26

27

28

29

30

31

32

33

34

35

36

37

38

39

40

41

42

43

44

45

46

47

48

49

50

51

52

53

54

55

56

57

58

59

60

61

62

63

64

65

66

67

68

69

70

71

72

73

74

75

76

77

78

79

80

81

82

83

84

85

86

87

88

89

90

91

92

93

94

95

96

97

98

99

100



⋮

-

⋮

⋮

⋮

⋮

⋮

⋮

⋮

-

⋮

1

⋮

.4

⋮

⋮

⋮

⋮

⋮

⋮

⋮

⋮

⋮

2

⋮

⋮

⋮

⋮

⋮

⋮

⋮

3

⋮

⋮

⋮

⋮

.30

- 1

.31

-

.32

- 3

² -Christine Vern, opcit, p 89.



1

:

•

⋮ ⋮ ⋮ ⋮ ⋮

⋮

⋮

⋮

⋮

⋮

⋮

⋮

•

⋮

⋮

⋮

⋮

⋮

⋮

⋮

⋮

⋮

⋮

⋮

•

⋮

⋮

⋮

⋮

⋮

⋮

⋮

⋮

⋮

()

⋮

⋮

⋮

⋮

⋮

⋮

⋮

⋮

⋮

⋮

2

⋮

² -Christine Vern, opcit, p 91.



.34
 1
 -1
 - 1

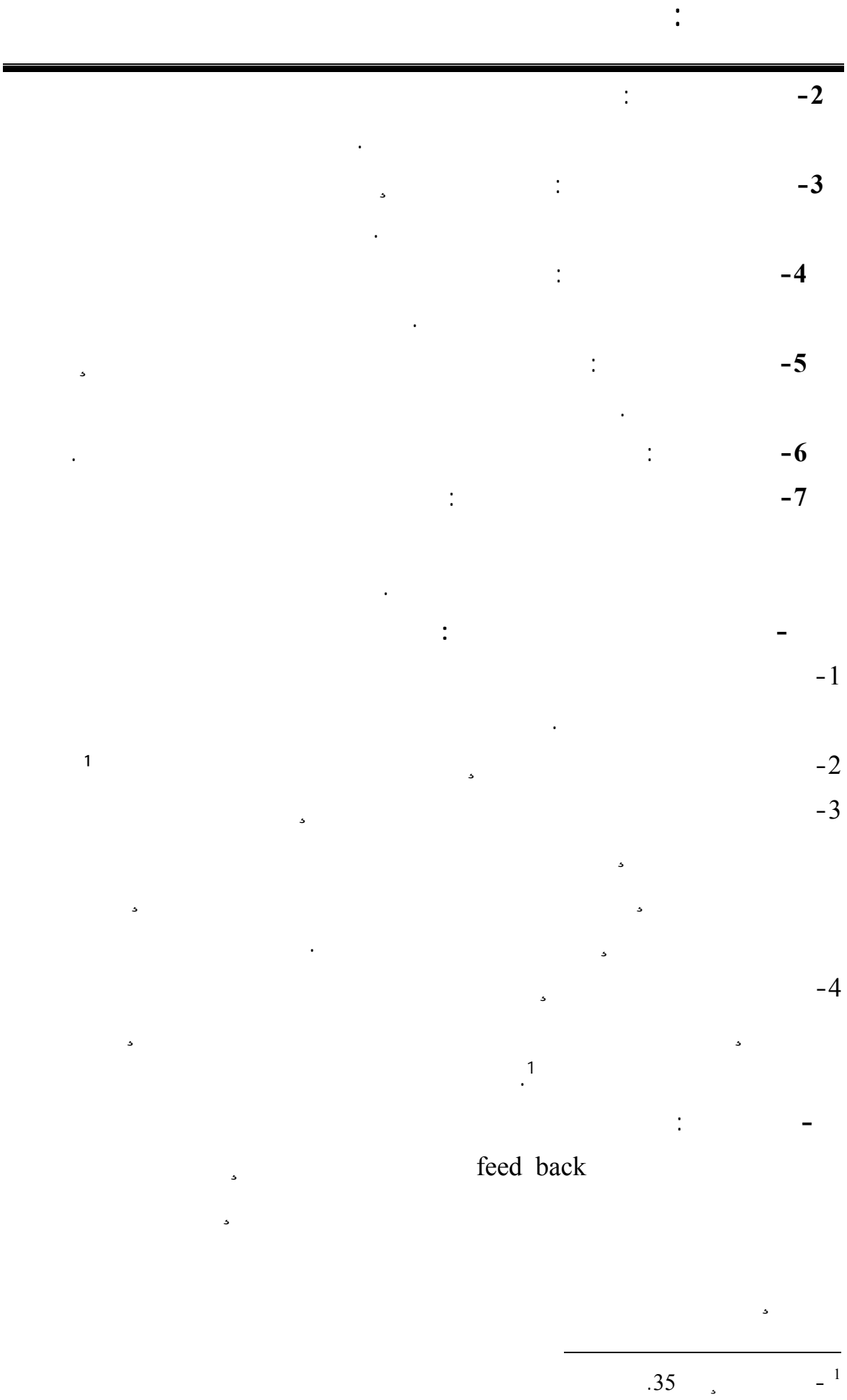

:



-1

(Kirk Patrick)

<http://www.shura.gov.sa.p2>

<http://www.annaba.org.pl>

.36

- 1

- 2

:



:

-1

:

-2

:

-3

(

)

:

-4

:

-5

(

)

:

.

:

-1

-2

-3

-4

¹ - Pell Arthur, opcit, p 163.
-Carre Henry, opcit, p39.
-Roussel Patrice, opcit, p165.
² - Lévy-Lefoyer Claude, opcit, p140.

:



:

-1

)

-2

.(

-3

-4

-5

-6

-7

-8

.1

:

.

:

-

-

-

-

-

-

-

-

-

-

-

-

-

-

-

⋮



- - - - -

.()

.1

:

:

:(23)

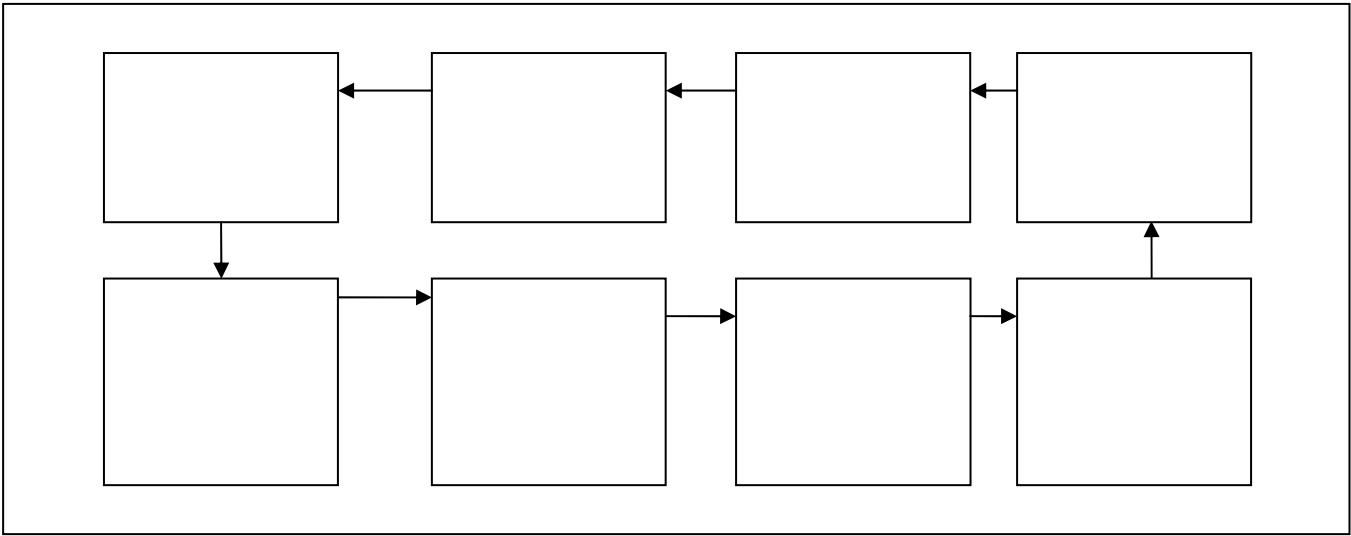

.118

1

()

-1

()

-2

()

-3

1

1

-6

(...)

.118

-1



⋮
⋮

⋮

⋮

⋮

⋮

⋮

⋮

⋮

⋮

⋮
1

⋮

⋮

⋮

⋮

⋮

⋮

⋮

⋮

⋮

⋮

⋮

⋮

⋮

⋮

⋮

⋮
9

⋮
1



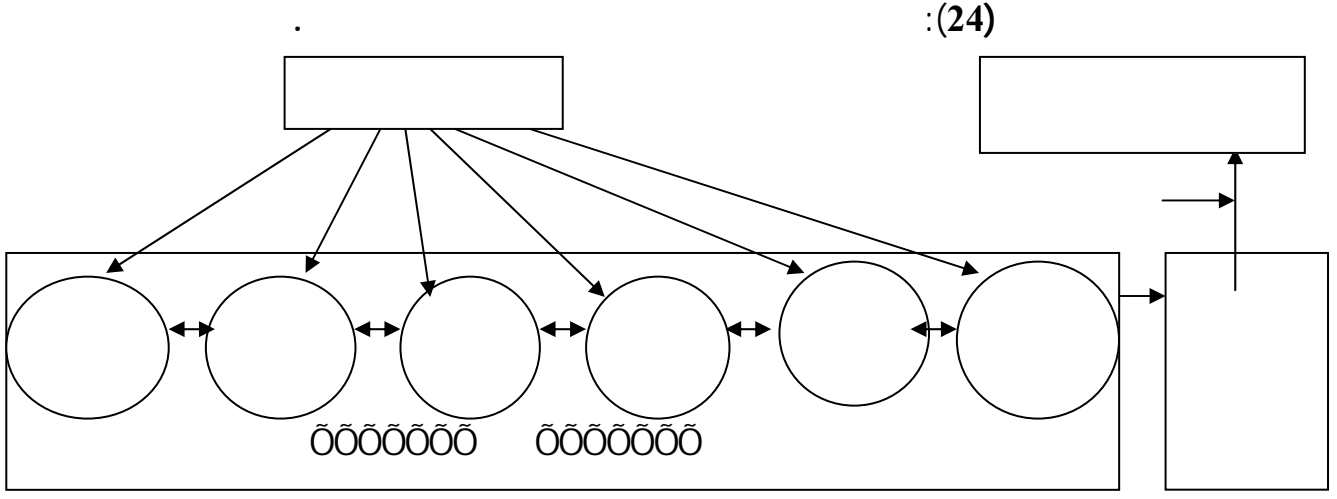

⋮



1



2



3



.24

- 1

- 2

.39 2003

- 3

2001

1

.21

1

.25

- 1

:



1



2

..

..

.

•

•

•

•

.70

.63

- 1

-

- 2

-Roussel Patrice, opcit, p27,35.
 - Levy-Leboyer Glaude, opcit, p138.
 - Aubin Nadia, opcit, p139.
 - Lapra Jean-Pascal, opcit, p55,68.
 - Bailly Frédérique Alexander et autres, Comportements Humaines et Management, édition Pearson éducation ,Paris, 2003, p161.

:



.....

- -

1

1¹

3

3

1

1

3

.

:

:

.

3

3

:

2

3

"

"

3

.27

.71

.102

- 1

-

- 2



:

%1 %100

:



1

:



:



2

- R.Schermerhorn John et autres, Comportement Humaines et Organisations, 2 eme édition, -- édition Village Mondial, Canada, 2002, p244.
- Froussier Jean Francois et Henri-Jacques, opcit, p203.
²- Roussel Patrice, opcit, p39.



..

..

.

3

.

3

3

.

(Benchmarking)

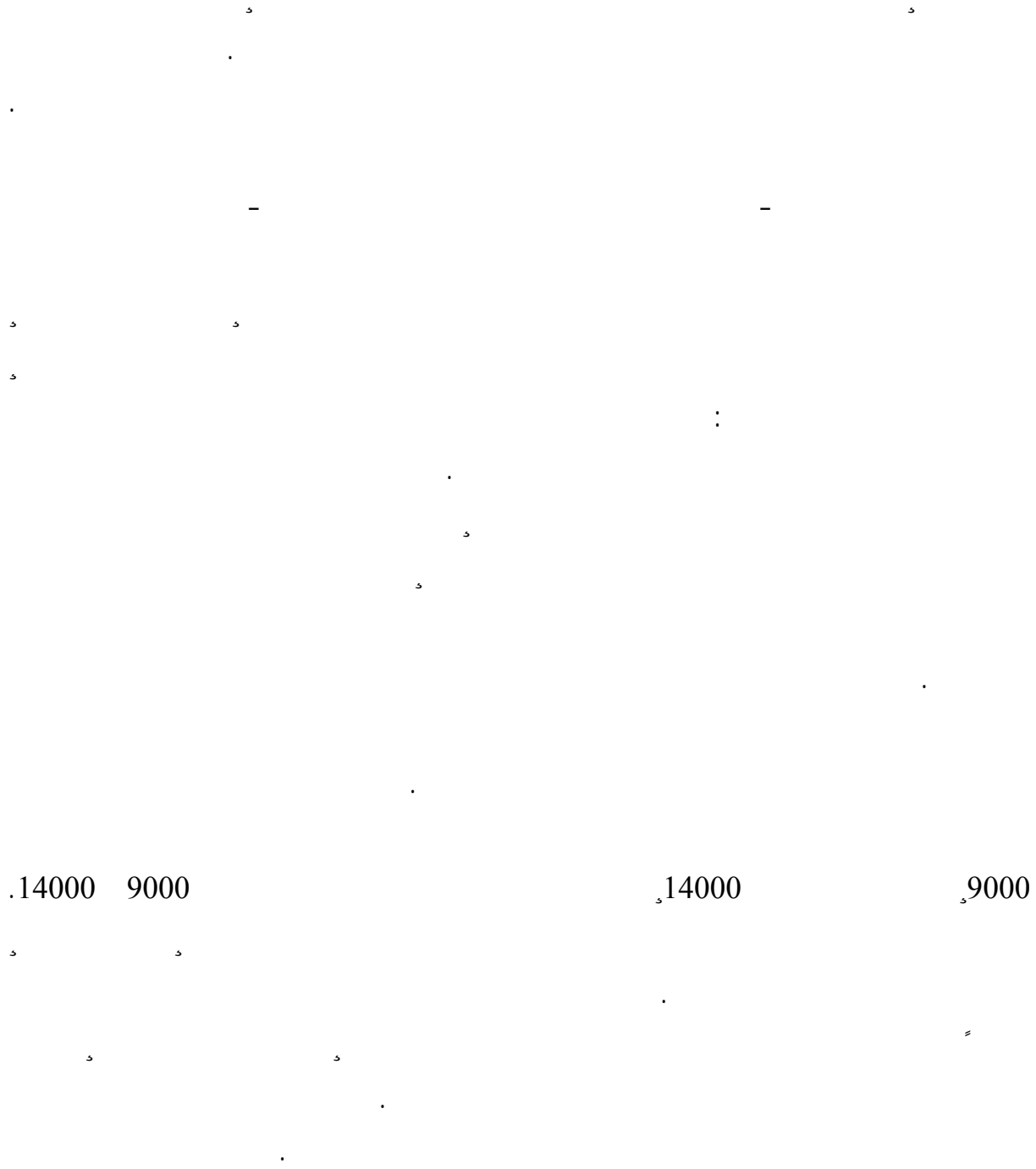

3

3

3

3

3

3

3

3

3

3

(TQM)

:

3

" :

1"

"

2"

3

4

.

.65

.66

.306

.165

-1

-2

-3

-4

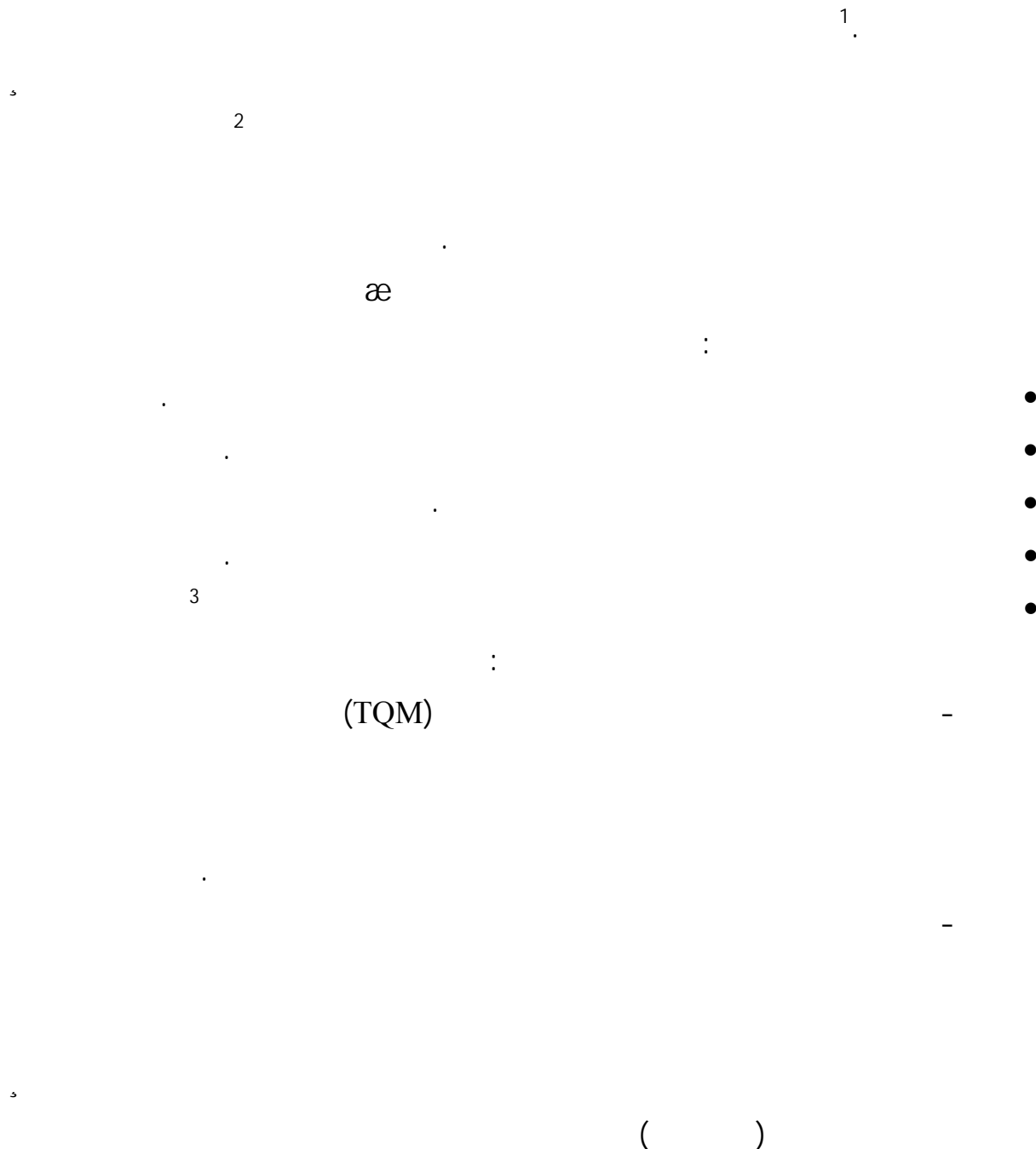

1 -Jin Collins, de la performance à L'excellence, village mondial pearson Education France, Paris 2003, P189

3 -2

.321 ,2001

www. inrs. fr. -3

.413 ,2002

1.

1

*

: (TQM)

-1

-2

-3

-4

(ISO 9000) :

-5

-6

-7

-8

-9

-10

-11

2.

-12

:

*

.193 2003

-1

: -2

156

-

-Anne Riberolles, op. cit, P 119.

- Marie Tresanini, Op. cit, P214.

1

2

0

-1

-2

www.balagh.com :

www.ipa.edu.sa

www.alsakher.com.



1

3

:

3

3

3

3

3

.

2

:

-

3

-1

3

.

3

-2

:

-3

3

.

-4

3

.151

3

3

-1

.151

3

3

-2



Fragmented text consisting of various characters and symbols scattered across the page, including dots, dashes, and numbers.

					-
					-9
					-10
1	.				-
:		:			-1
					-2
					-3
					-
					-
					-1



: (Edward Deming)

) -1

1

(

-2



-3

-4

-5

-6

*



:

:

*

3

3

.

3

.

3

-3

.1

.159*162

-1

.04

-

: (25)

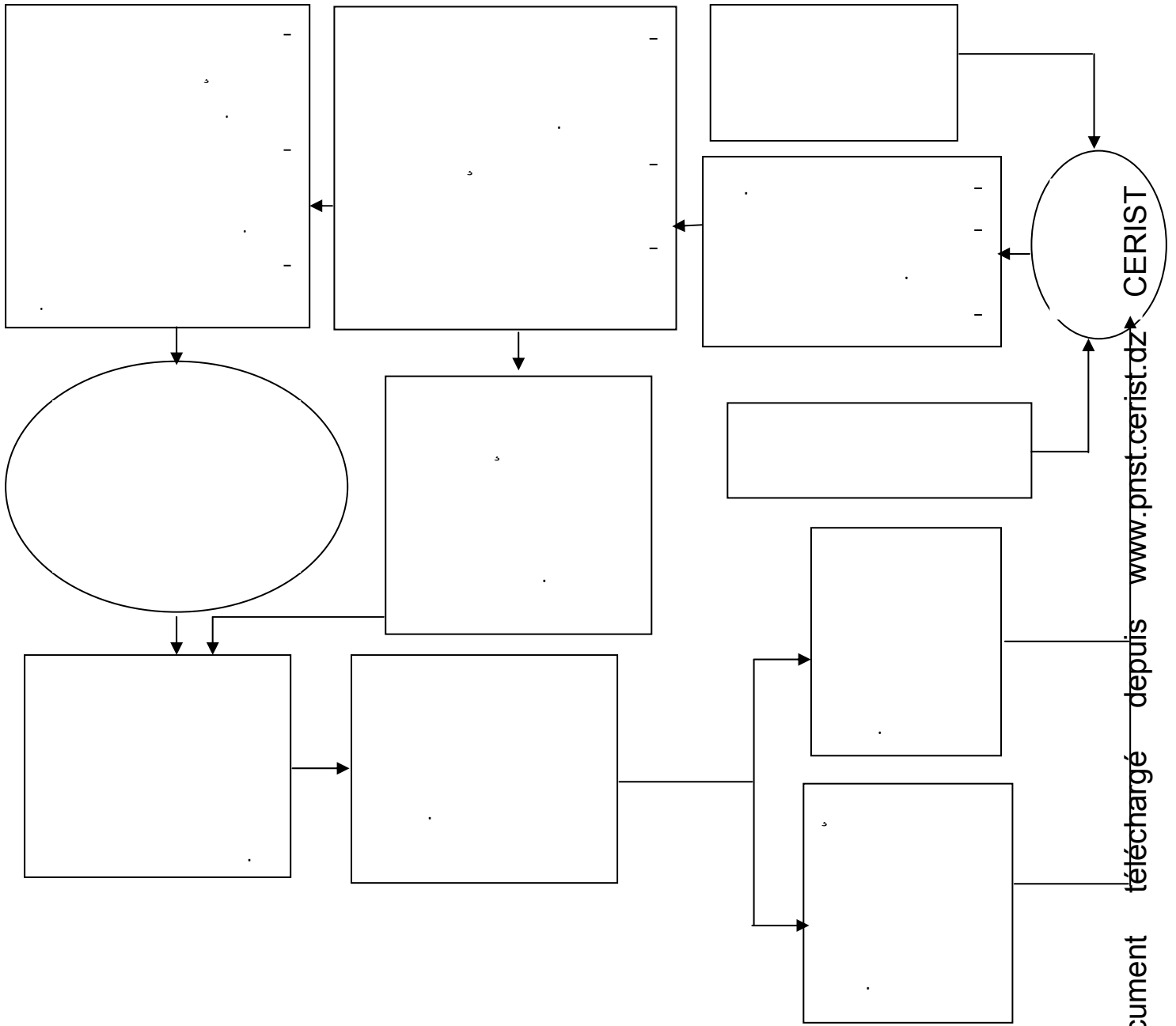

CERIST

www.pnst.cerist.dz

Document téléchargé depuis

.155

9000
14000 9000

°9000

.(14000 9000)

9000

:

(ISO9000)

() (BS5750) (EN29000) (ISO9000)
1987

(ISO9000)

(BS5750)

.¹(EN29000)

9000

9000

9000

9000

: ISO9000 •

: ISO9001 •

: ISO 9002 •

: ISO9003 •

Document téléchargé depuis www.pnst.cerist.dz CERIST

: -1

43 -

.56 2005 9-8

14000

.(ISO)

14000

1

:14000

*

:14001

*

:14004

*

:14010

*

:14011

*

:14012

*

: 14013

*

: 14014

*

: 14015

*

: 14020

*

: 14031

*

: 14040

*

2

: 14060

*

: 14001

*

1996

14000

1993

14000

14000

14001

:

186

-1

.356

-

.192 ,187

-2

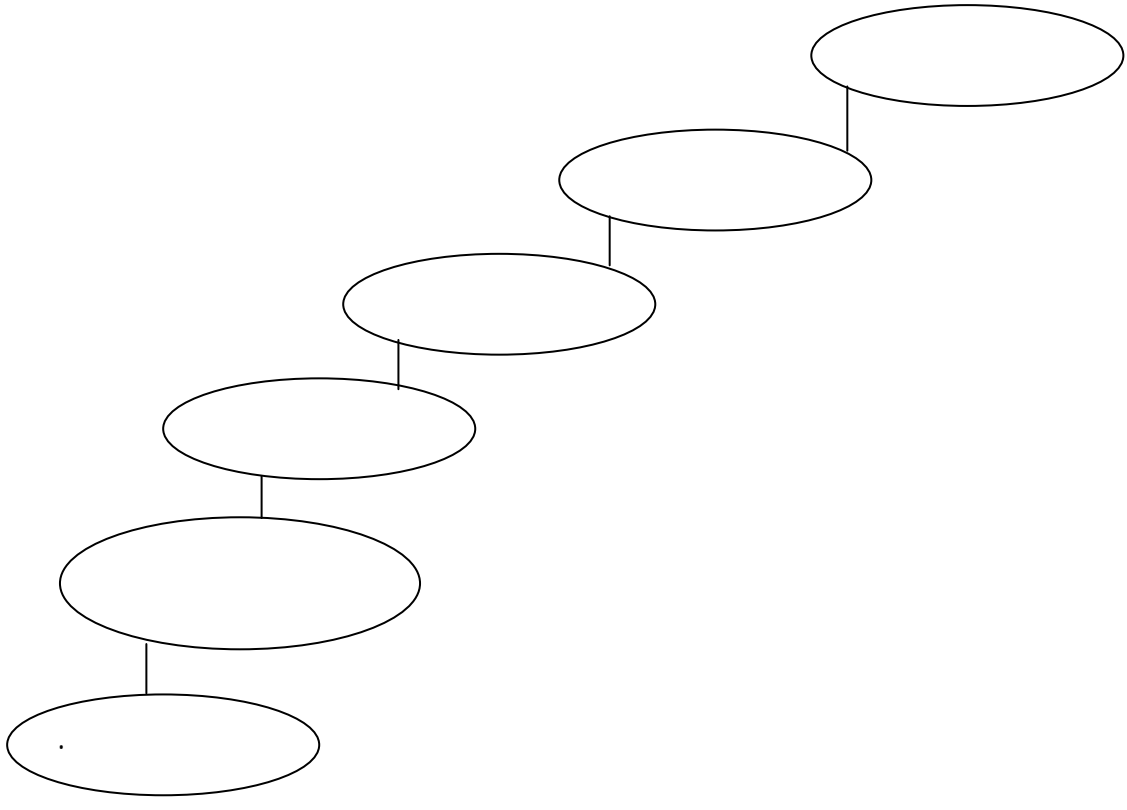

.14000

:(26)

:

.1

-
-
-
-
-
-



:

. 1

: 14000

.194

-1

Document téléchargé depuis www.pnst.cerist.dz CERIST

	-1
	-2
	-3
	-4
	-5
	-6
	-7
	-8
	-9

Document téléchargé depuis www.pnst.cerist.dz CERIST

(9000,9001,9003,9004)

.9000

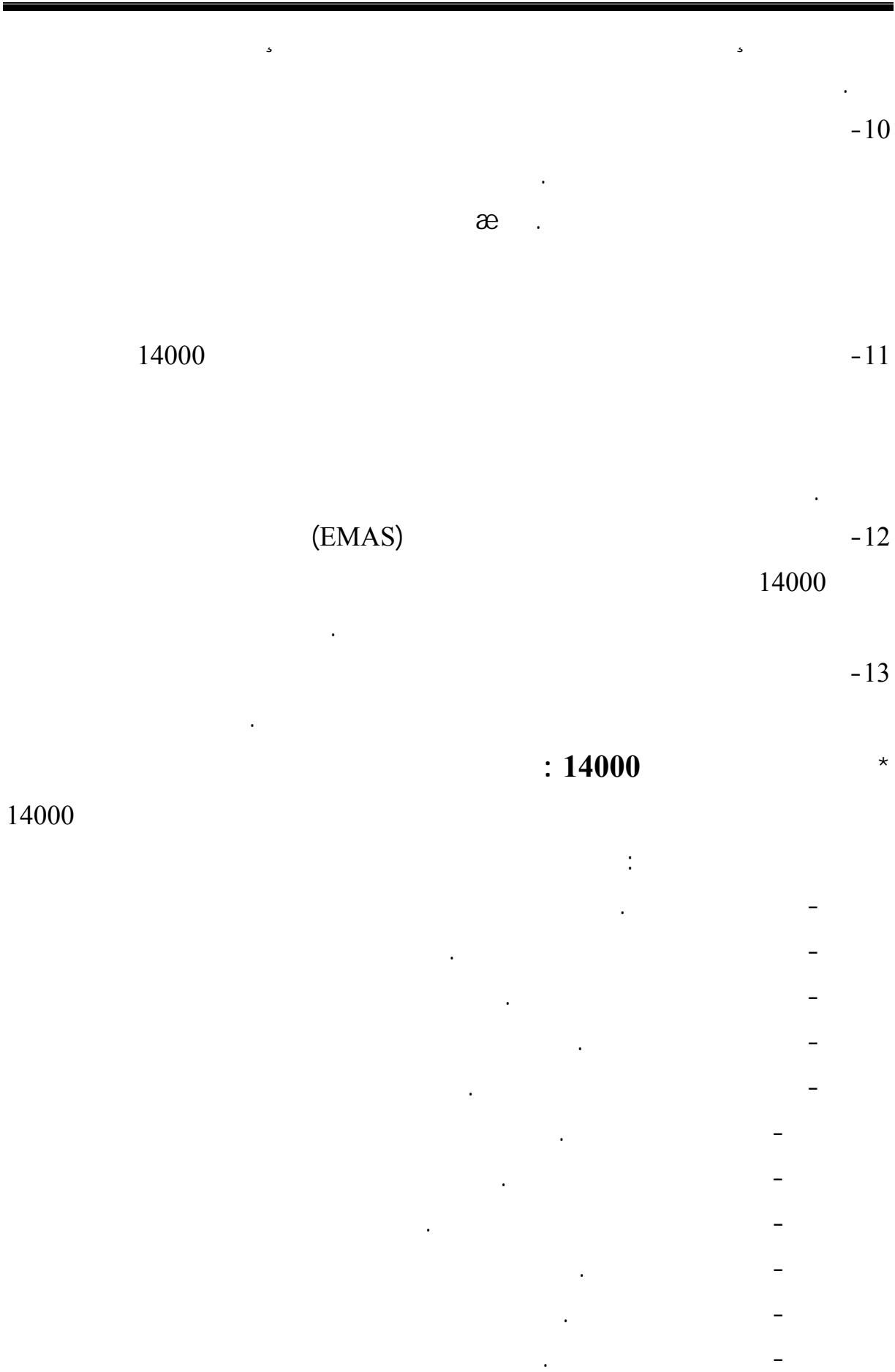



-

-

-

-2

-3

- 4

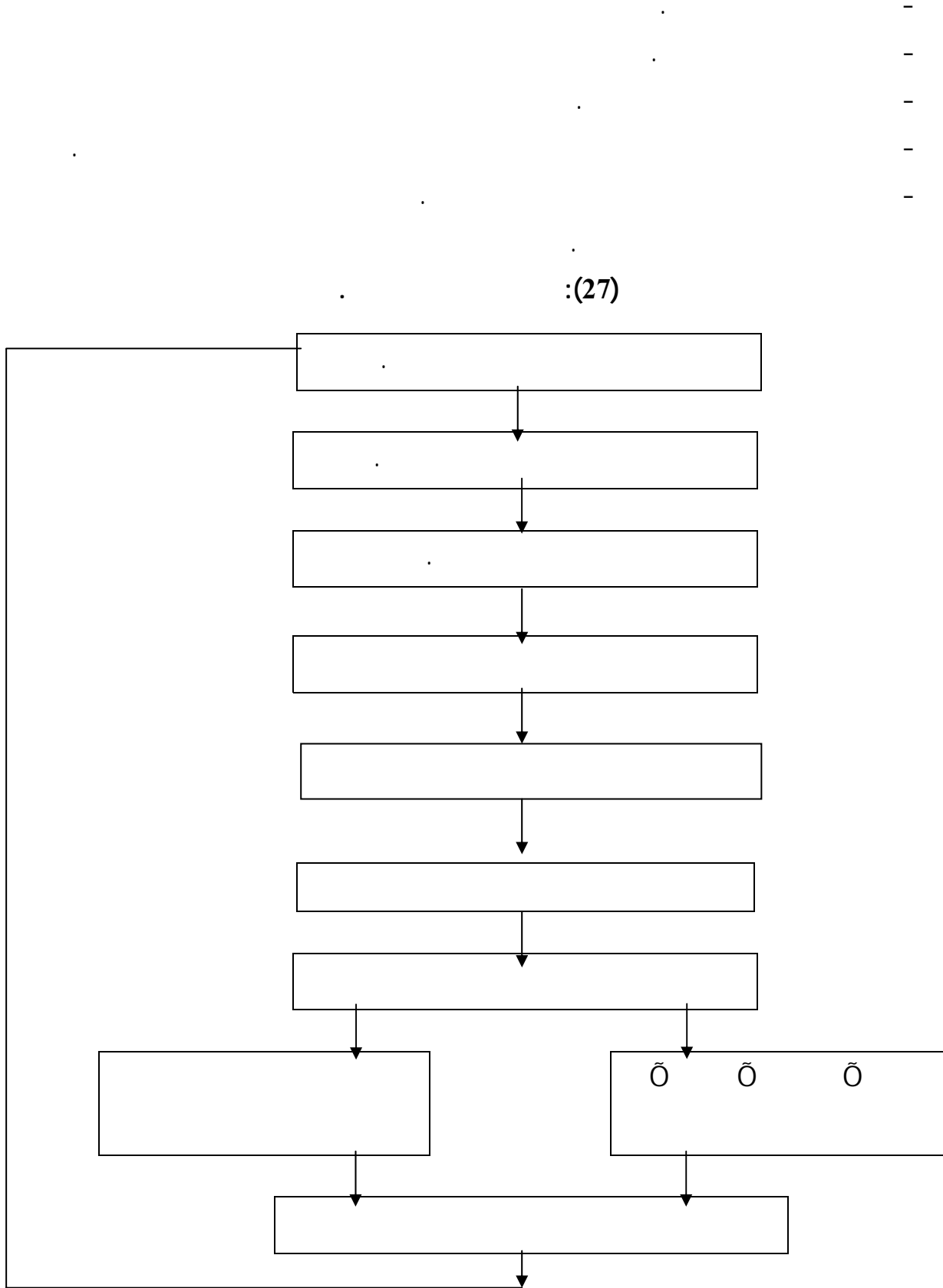

:(27)



:

-5

5

-

-

5

.

:

:

-6

.

.

.

-

-

-

-

-

-

-

-

-

-7

:

:

,

-

-

-

-

-

-8

:

5

5

5

	:	-9
	:	-10
	:	-11
	:	-12
	:	-13
()	:	-14
æ :	:	-15



() : -16

() : -17

- - : -18

o o o

: -19

() : -20

.1400 9000 1

: *

.174 -1

.417 -

.()

()

.211

-1

-2

-1

-3

-4

:

-5

-6

-7

-8

æ

-9

-10

-11

-12

1

:

*

()

2

: -1

- John R. Schermerhorn et autres, opcit, P147 , 153.
- Frédérique Alexandre – Bailly et autres , opcit, P 158.
- Robert Bacal, opcit, p 169 , 203
- Nicole Aubert et Mickael Hoffmann – Herve, op cit, P240, P245.
- Jacques – Henri Jacot, et Jean – François Troussier, op cit, P203

:(8)

Automation	T.Q.M	Restructring	Rightsiging	Reengineering	

.210

:

()

*



- - - - -

*

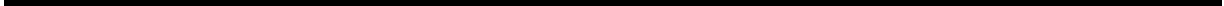

.1

..

*

*

*

*

*

-



" ()

1.

: ()

(1

:

:

()

-

:

-Ö

(2

-

:

•

-
-
-

: (28)

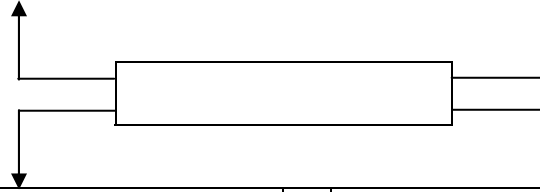

.57 2001

(3

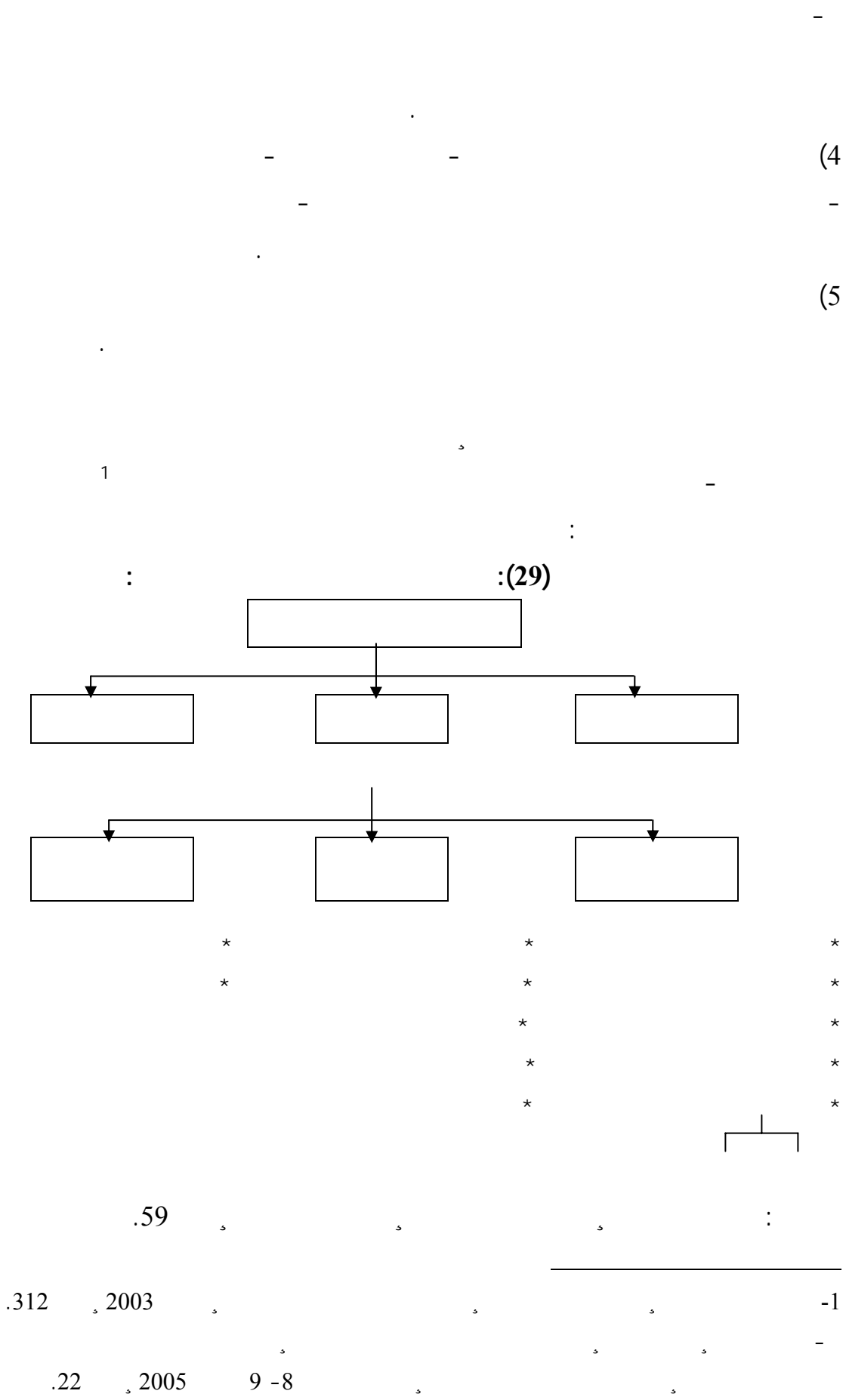

:

:

-1
-2
-3
-4

(....

1

-
-
-
-
*

.68

-1





1 -Debra.m.Amidon.Innovation et Management des Connaissances, édition d'organisation, paris 2001 , P 182.



:

(..... s s)

:

-1

-2

-3

:

..

..

..

.

.

-

-

-

-

-

-

-

-

-

-

-

-

.
 - : : -
 :
 :
 . -
 . -
 . -
 : : -
 -
 -
 " .

 1"
 2 .
 :
) : -1
 (.
 :
 :

Document téléchargé depuis www.pnst.cerist.dz CERIST

2 -Jean Pierre Anciaux, le savoir en Action des Connaissances à la performance, les éditions d'organisations, Paris, 1996 , P 312

← ←

:

•

•

•

•

•

¹(Danial et C. Sales)

:

-2

"

"

3

:

-

-

-

:

:

:

:

:

•

•

•

:

-1



1

.12 2002

.445 2003

- Alain Vicen, op.cit, P 129.

.15 2000

.249 1999

.290 1993 ()

.

:

•

•

•

•

1

:

3

3

3

:

-

-

-

-

-

-

-

-

-

-

-

-

-

-

-

-

-

-

.39

-1

.25

2005

10-9

.15 1994

:

-
-
-
-

1

::

()

: (30)

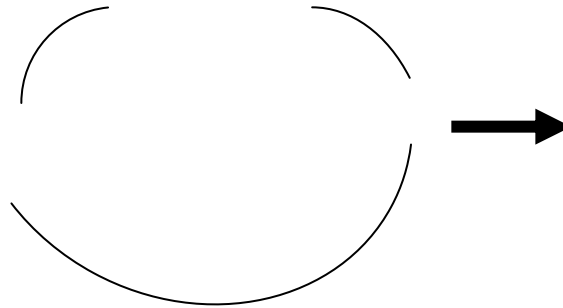

. 103

()

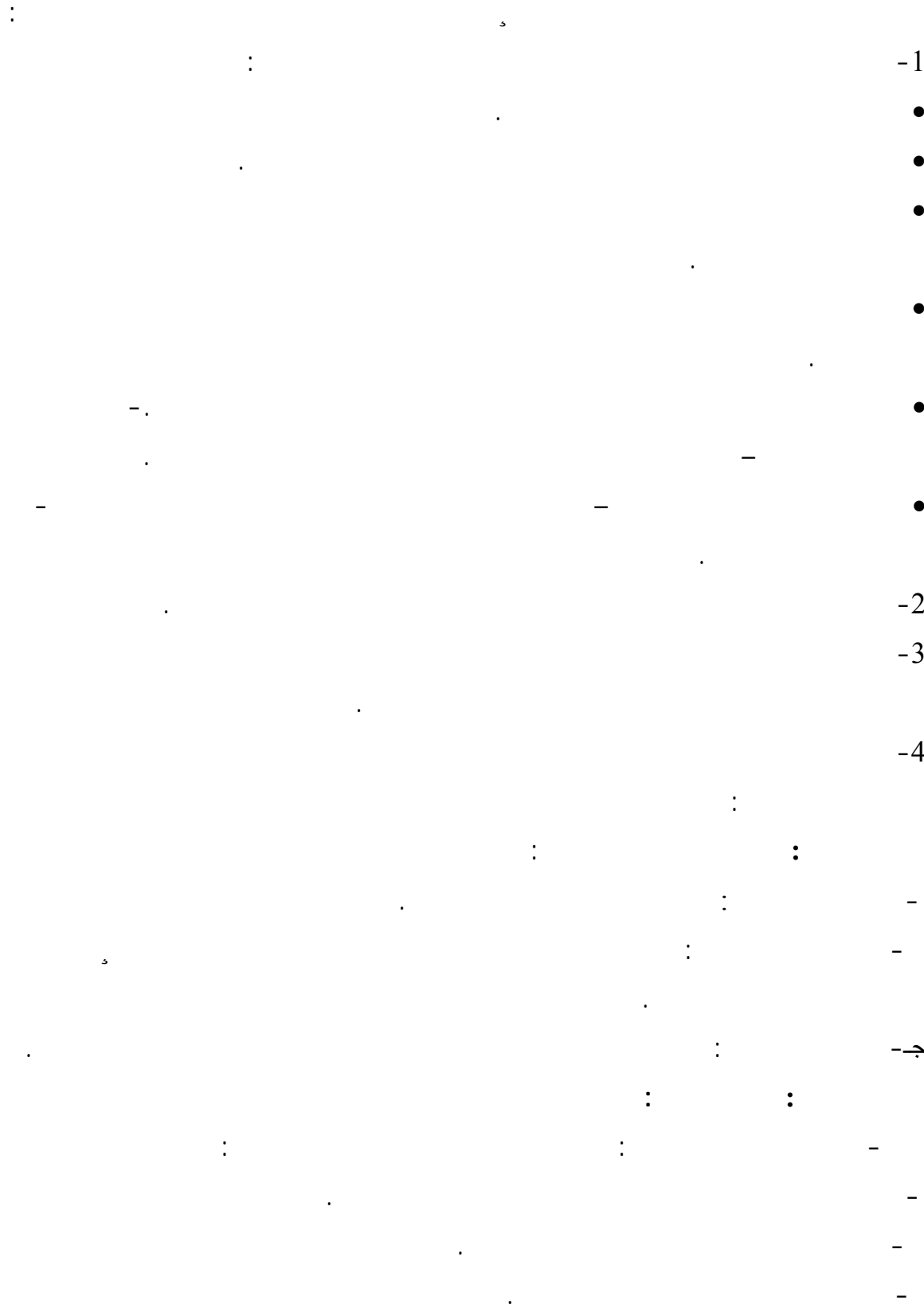

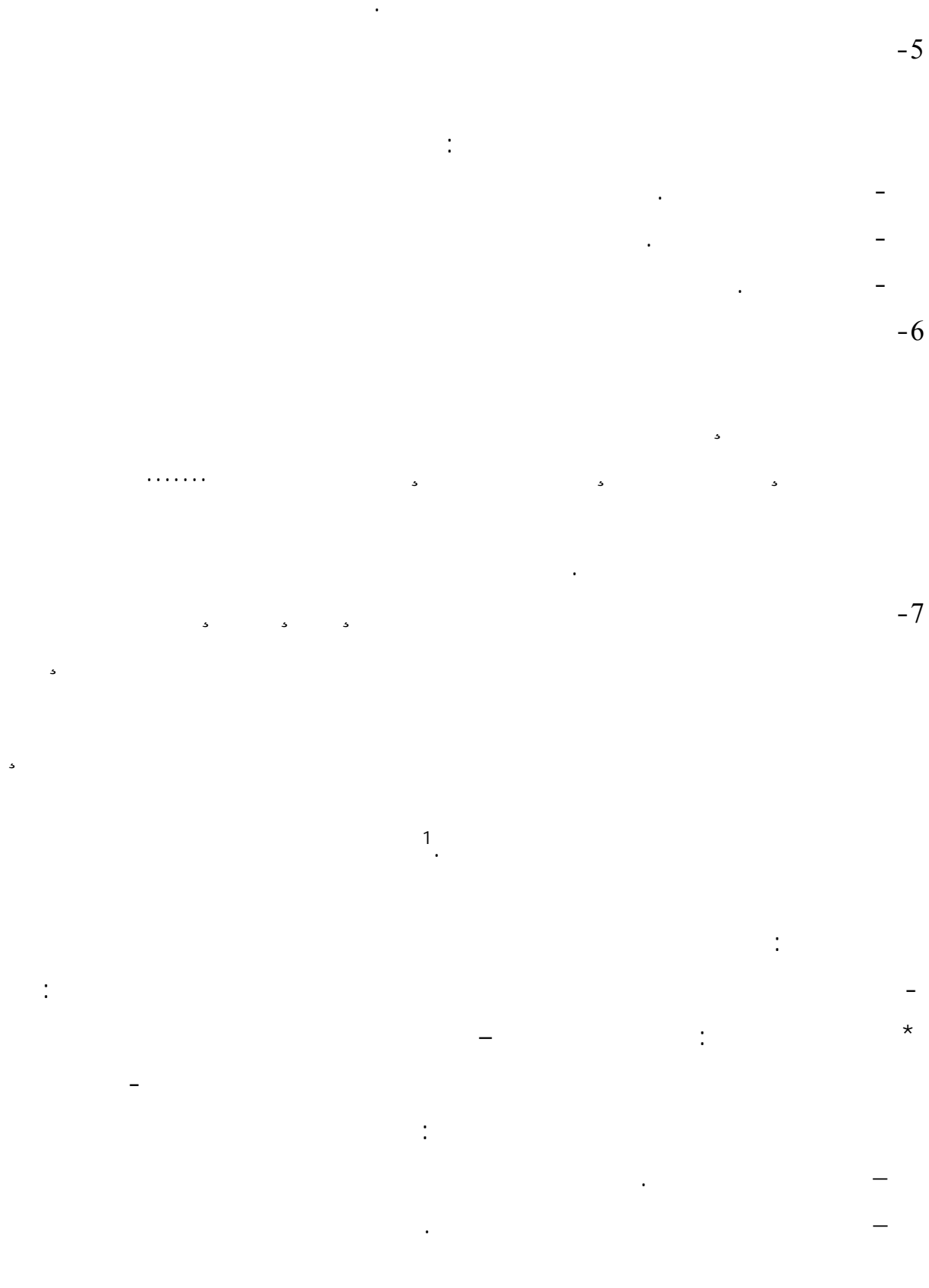

-5

-6

-7

¹- Arthur Pell, op.cit, P 158 , 159.
 - Claude L'evy – Leboyer, Opcit, P 140.

:(9)

	• • • •	
	• • •	
	• •	
	•	
	• •	
	• • •	
	•	



: (31)

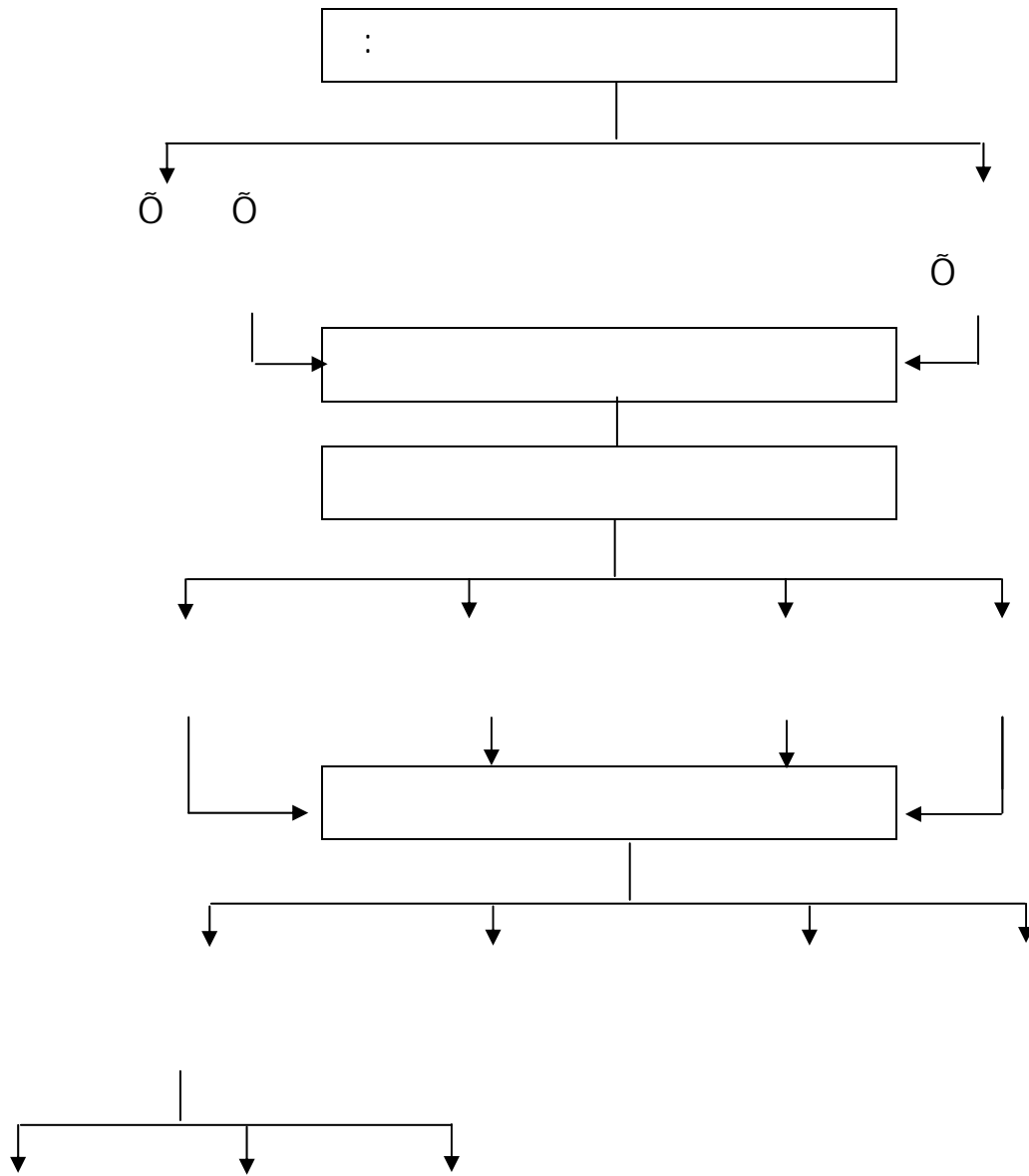

.184

:

*

:

:

-

-1



1.()

æ

194 192

-3

-4

-5

-1

-

()

1

()

1947

: 0

1969

26

(59 - 69)

1969

01

(SONEL GAZ)

[1949 - 1947] (EGA)

.()

1983

1983

: KAHRIF

: KAHRAKIB

: KANAGAZ

: INERGA

: ETTERKIB

: AMC

1991

SONEL GAZ : Société Nationale d'électricité et de Gaz.

(1991 14 475 - 91)

1983

:(Sonel Gaz Epic)

1995

1995 17 280 - 25

()

01

195 - 02

: (SONELGAZ. SpA) **2002**

(SONELGAZ)

2002

: Õ

(SONELGAZ. SpA)

150 000 000 000

Ö

:

:

:

:

:

:

:

:

.

.

.

.

.

.

.

.

.

.

.

.

.

.

.

.

.

.

: (32)

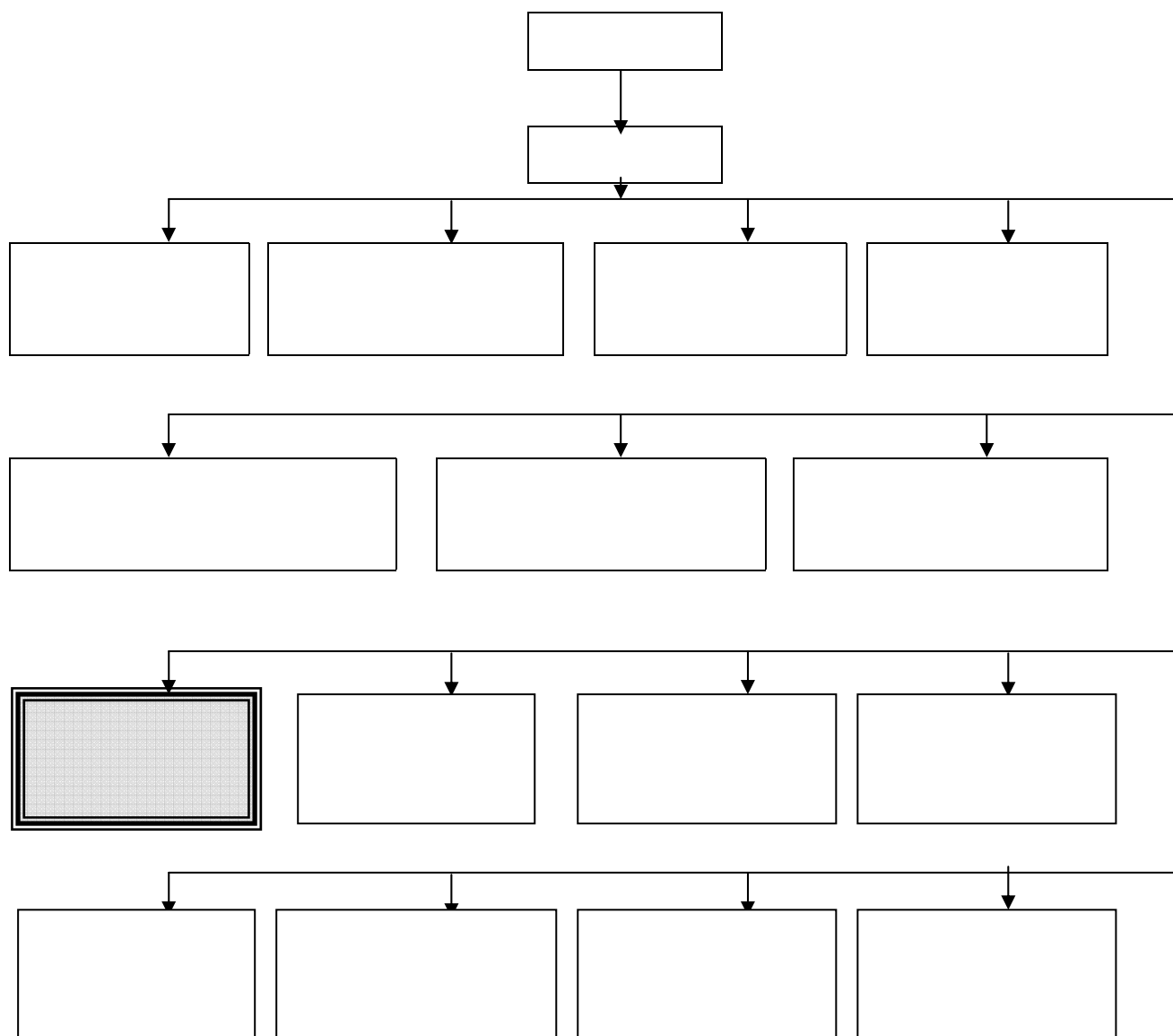

:(33)

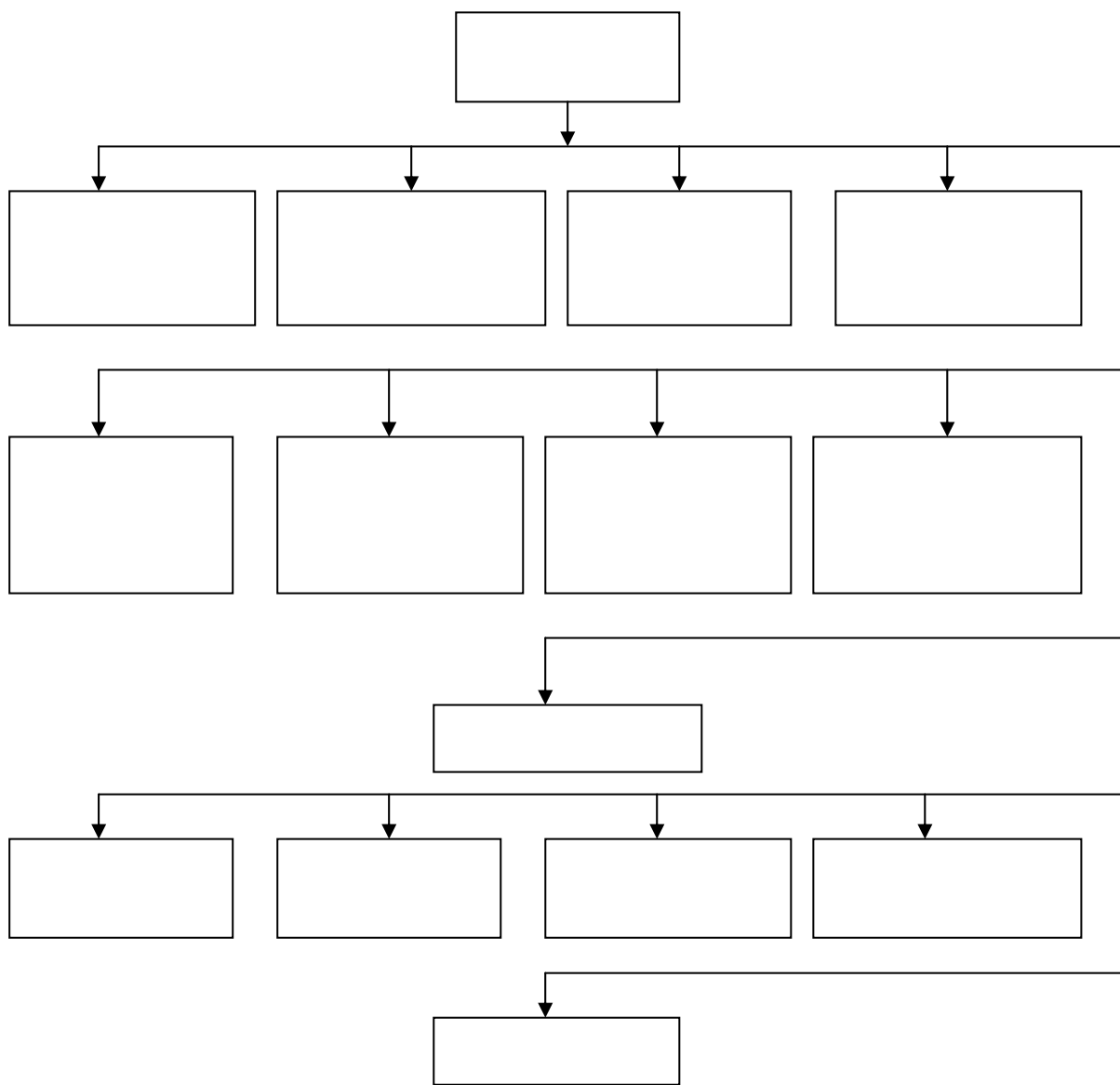

:(10)

2006	
21230	
% 21 % 48 % 31	}

21230 : Õ

65

28 .

* * * * *



(Variable) (SPSS) () (Cases)

(SPSS)





:

-3

(7)

: 01

:

: 02

20

5

15

4

$$\frac{\quad}{4} = \quad$$

: 03

(x)
(4 3 2 1)

- 11 -

:(11)

	1
	2
	3
	4

(12)

(4 3 2 1)

:(12)

2 - 0	0	1
4 - 3	3	2
6 - 5	6	3
8 - 7	10	4

(5)

(10)

(0)

.(20)

: 04

(%60) ()

(% 40)

$0,4 \times (\quad) + 0,6 \times (\quad) =$

: 05

: 06

: 07

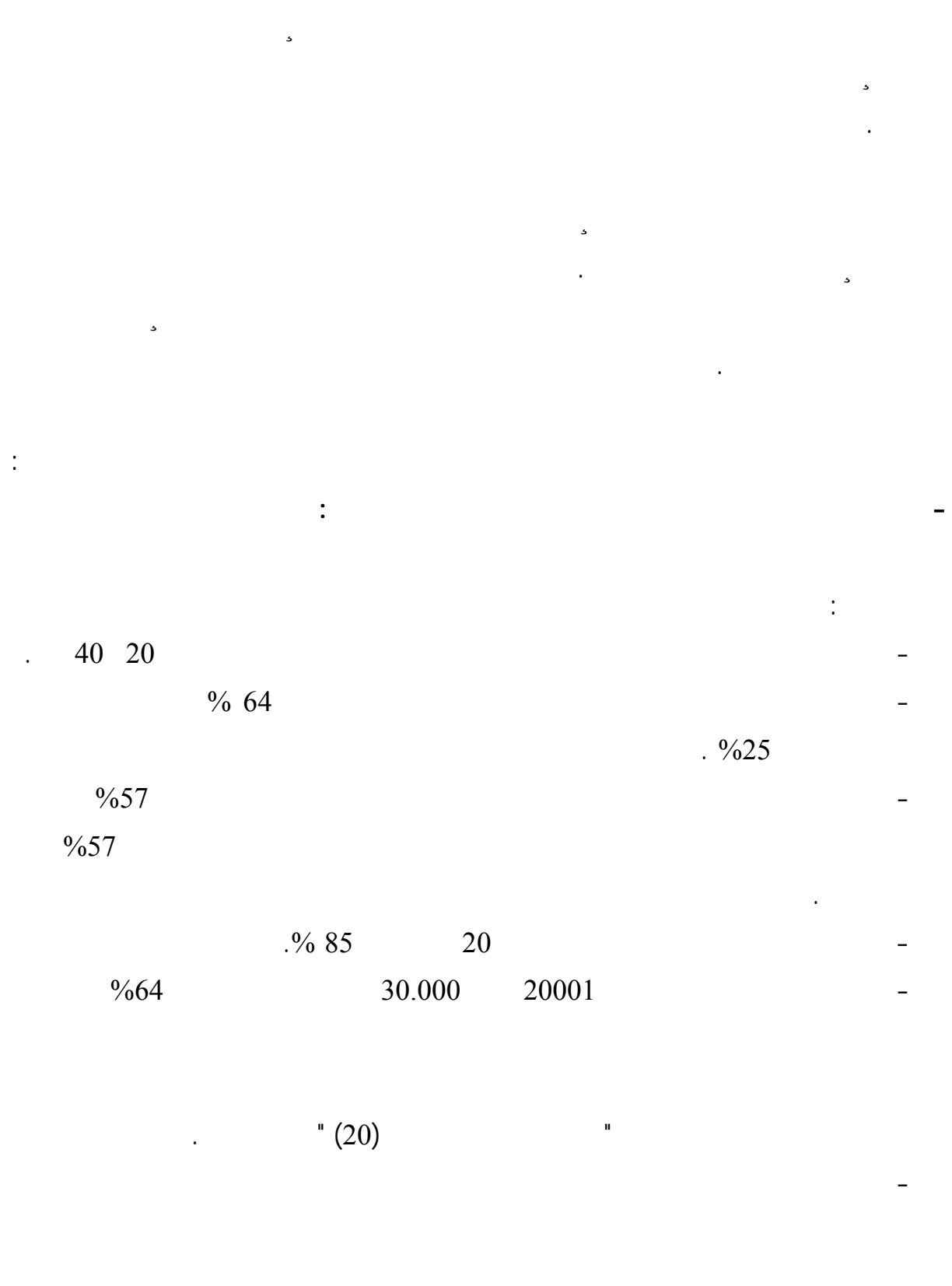

د

:

:

:(34)

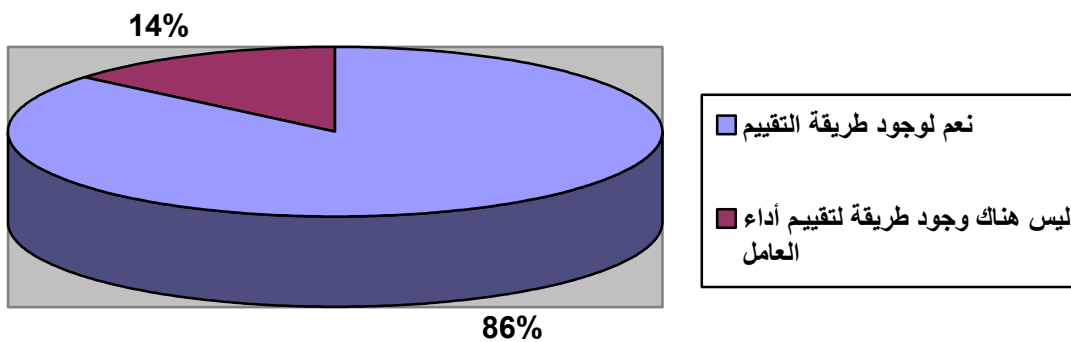

% 14

د

د

د

د

د

د

د

.

:(35)

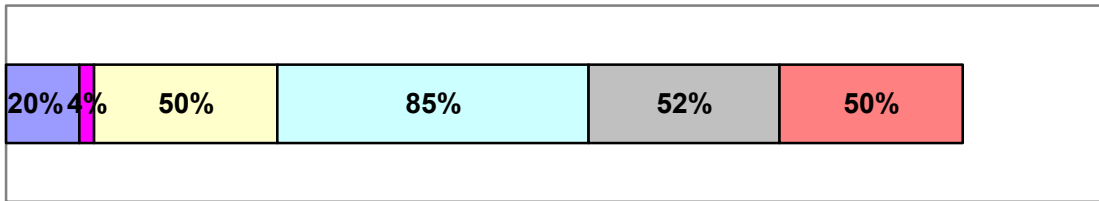

:(36)

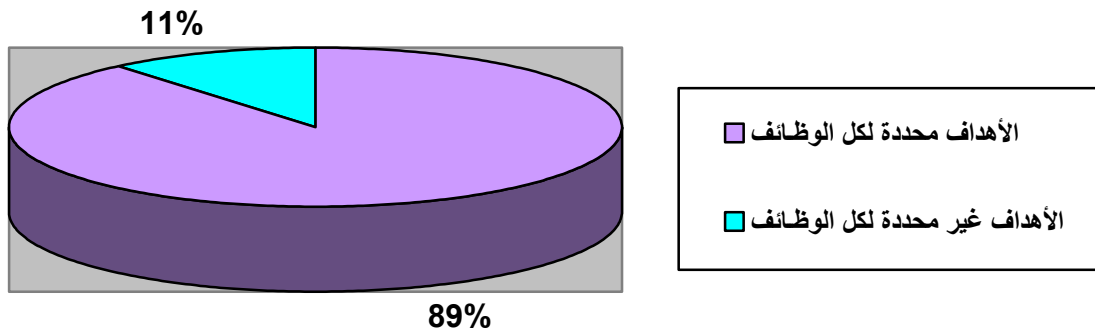

:(37)

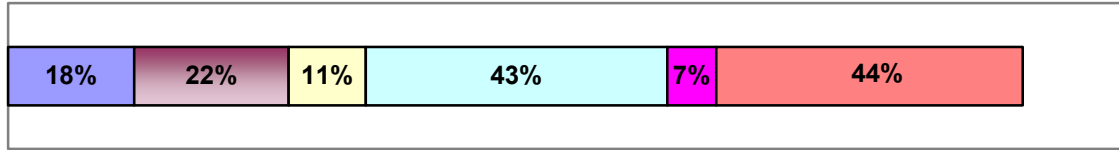

■ أهداف واضحة محددة وموضوعية وسهلة المنال	■ أهداف واضحة محددة وطموحة وصعبة المنال
□ أهداف عامة مبهمّة أي تخضع لمجموعة من التفسيرات	□ أهداف مرتبطة بالعمل يمكن قياسها كالتنتائج المحققة من العمل
■ أهداف مرتبطة بالعمل لا يمكن قياسها كالسلوك في العمل	■ أهداف مرتبطة بالعمل يمكن ملاحظتها في العامل المؤدي للعمل

% 41

:(13)

% 59		
% 5	-1	
% 9	-2	
% 14	-3	
% 50	-4	
% 22	-5	
% 79	-	
% 72	-	
% 75â	-	
% 61	-	
% 46	-	
% 46	-	
% 36	-	
% 50	-	
% 50	-	
% 29	-	
% 36	-	
% 39	-	
% 18	-	
% 39	-	
% 50	-	
% 36	-	

:

:

:(14)

% 41	
% 48	
% 65	
% 48	
% 21	
% 52	()

::

%52

% 35

% 48

%79

()

:(38)

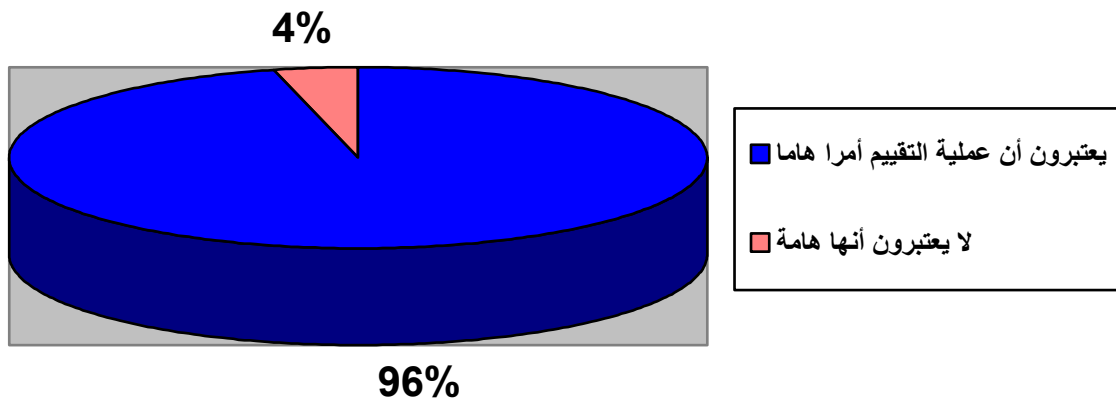

% 4

% 96

:(15)

نعم	البيان
% 63	- هل يتم رسميا تقييم جميع العاملين مرة في السنة - في حالة الإجابة لا : التقييم على فترات :
% 19	- شهرية
% 06	- فصلية
% 75	- سداسية
% 39	- هل تعتبر أن التقييم مرة في السنة كاف للحكم على كفاءة وفعالية أداء العاملين. - في حالة الإجابة لا : ما هي الفترة المفضلة :
% 33	- كل شهر
% 17	- كل 3 أشهر
% 11	- كل 4 أشهر
% 39	- كل 6 أشهر
% 79	- هل تفضل أن تجري عملية التقييم بصفة مستمرة. - في حالة الإجابة بنعم : ما هو سبب ذلك.
% 54	- ارشاد العامل وتوجيهه بشكل مباشر في ضوء أدائه.
% 36	- زيادة دافعية العاملين للعمل.
% 39	- تعريف العامل بنواحي الضعف لتجنبها.
% 36	- تمكين العامل من فرصة استدرالك أخطائه قبل اتخاذ قرار بحقه

% 63

% 75

- % 79

:(39)

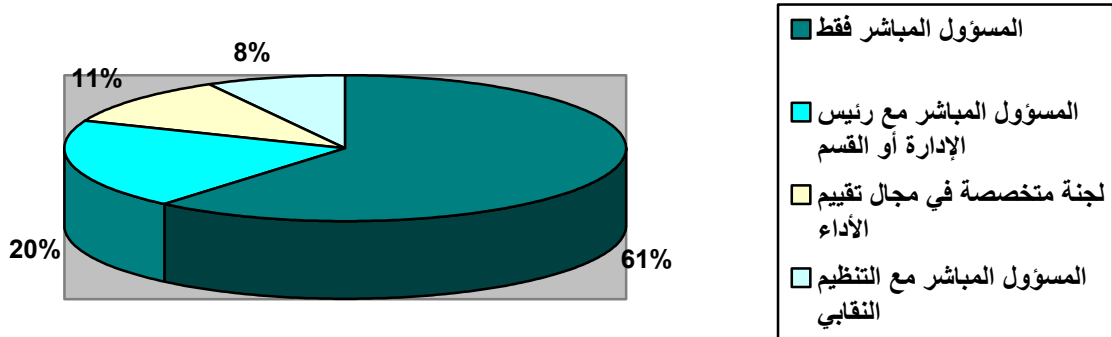

%61

%20

:(40)

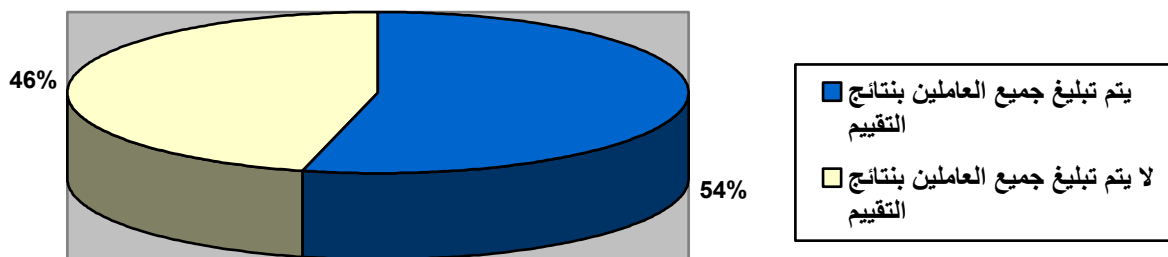

54% من

:

:

: (41)

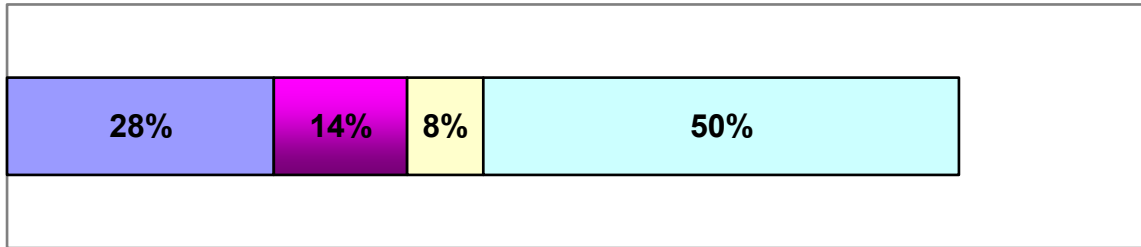

العننية للتقديرات ذات الدرجة المنخفضة فقط □ العننية للتقديرات المرتفعة فقط □ العننية □ السرية التامة □

%50

æ

%28

:(16)

% 57	o
%46 %07 %33 %14	- - - -
%54 %14 %07 %25	- - - -
%18 %36 %46	- - -
%65 %14 %14 %07	- - - -
%0 %10 %51 %4 %10 %25	- - - - - -
%15	
%98	
%42 %16 % 16 %26	- - - -

%57

%79

%79

%46

%18

%36

%.65

%51

%25

%15

%98

.5 = 2 + 2

$$4 = 2 + 2$$

%100

-

%48 -

:

-

:

:(17)

% 89	o	
%28	o	-
%11		-
%25 %18 %57	o	- - -
%78	o	-
%14 %36 %48	o	- - -
%80		-

:

%28

%89 Õ

.% 57

%48

%36
%80

(....)

.

.

.

.

.

.

.

..

..

.

.

.

.

.

-

-

)

.

.

.

.

.

.

.

-

-

-

-

-

-

-

-

-

-

-

-

-

-

-

-

-

-

-

-

-

-

-

-

-





:

()

3

3

3

3

3

.

Ô

Ô

æ

”

“

-2

: Ô

: .I

2003. -1
" " -2
.2002 -3
.2003 -4
.1998 -5
.2001 -6
.2000 -7
.2000 -8
.1989 -9
.2003 -10
() -11
.2003 -12
.1998 2 -13
.2002 -14
.1996 -15
.2001 -16
.1999 -17
.2003 -18
() -19
.2003 -20
.1998 -21
.2002 -22
.2000 -23

.05	.21	-24
		.2000
	:	-25
		.1991
		-26
		.1994
()	-27
	.1998	
.2004		-28
		-29
	.1997	
	.21	-30
.2001		.2001
.1999		-31
		-32
		-33
.1991		.2002
		-34
		-35
.2003		.2002
		-36
		-37
	.1998	.06
		-38
	.1990	
()	-39
	.1999	.1993
		-40
		-41
	.2000	
		-42
	.2002	
	%1	-43
	.1999	
		-44
	-	.1998
(-	-
)		-45
	.2000	
		-46
	.1995	.06
		-47
	.2003	

	-48
.2004	-49
	-50
.2003	-51
.1999	-52
.1999	-53
	-54
.1998	

- 1- Alain vican, concevoir le système d'information de l'entreprise, les éditions d'organisation, Paris 1993.
- 2- Anne RIBEROLLES, Evoluer vers un nouveau dialogue en ressources humaines, Edition Achevé d'imprimer sur les presses de Jouve, N° 1292, France 1992.
- 3- Arthur Pell, encadrer et motiver une équipe, édition: les échos, village mondiale, paris 2001.
- 4- Aubert Nicole et Michael Hoffmann Hervé, diriger et motiver, édition d'organisation, paris, 2000.
- 5- Aubin Nadia, évaluation j'ai la cote, édition: d'organisation, paris 2002.
- 6- Christine Vern, l'évaluation des compétences, édition liaisons, paris 2002.
- 7- Claude Levy - Leboyer, évaluation du personnel : quels objectifs ? quelles méthodes ? éditions d'organisation, 3^{ème} édition, Paris 2001.
- 8- Claude Lévy – leboyer , la motivation dans l'entreprise, édition d'organisation, paris 2000.
- 9- Debra .m .Amidon, Innovation et Management des Connaissances, édition d'organisation, Paris 2001.
- 10- Denis Molho, la performance globale de l'entreprise, édition d'organisation, Paris 2003.
- 11- Dunod, stratégie d'entreprise et communication, édition d'organisation, Paris 1992.
- 12- Frédérique Alexander Bailly et autres, Comportements Humaines et Management, édition: Pearson éducation, Paris 2003.
- 13- H .Miser + E.S Qualle, Hand Book of Systems Analyses: Graft Issues and procedural chores, J.Wily, 1988 (N.y).
- 14- H. Miser + E.S Qualle, Hand Book of Systems Analyses: overview of uses, applications, procedures and practice, North, Holland,1985.
- 15- Hamady. H.M, Administrative réform in developing countries with special reference to Egypte and lybia, P.H.S this is University of strathclyde-Glasgow, 1975.
- 16- Henry carre, Diriger des salariés aujourd'hui, édition: maxima leurent du mesnil, Paris 1991.
- 17- Jacques Barraux, entreprises et performance globale, economica édition, Paris 1997.
- 18- Jacques Henri Jacot, Jean François troussier, travail, compétitivité performance, édition: economica, paris 1992.
- 19- Jean – pascal lopra, l'évaluation du personnel dans l'entreprise, édition: Dunod, paris 1993.

- 20- Jean Pierre Ancieux, le savoir en Action des Connaissances à la performance, les éditions d'organisations, Paris 1996.
- 21- Jean Pierre Mercier, Mesurer et Développer les performances, les éditions A Quebecor, monte Real , 2003.
- 22- Jin Collins, de la performance à L'excellence, village mondial pearson Education, Paris 2003.
- 23- John. R. Schermerhorn, Richard. N. Osborn, Comportement humain et organisation, édition : village mondial, 2^{ème} édition, Canada 2000.
- 24- John R. Schermerhorn et autres, Comportement Humaines et Organisations, 2 eme édition, édition: Village Mondial, Canada 2002 .
- 25- Jon Katzenbach, Douglas Smith, les équipes haute performance, édition: Dunod, Paris 1994.
- 26- Marie Tresanini, Evaluer les compétences, édition EMS Management & société colombelles, Paris 2004.
- 27- Michel Darbelet, Laurent Izard, Michel Scaramuzza, Economie d'entreprise, collection tertiaire, édition: Foucher, Paris 1995.
- 28- Patrice Roussel, Rémunération, Motivation et satisfaction au travail, édition: economica, Paris 1996.
- 29- Robert Bacal, Améliorer les performances de son équipe, maxima laurent du mesnil éditeur, France 2001.
- 30- Yves Emery, François Gonin, Dynamiser les ressources humaines, presses polytechniques et universitaires romandes, Paris 1999.

									.II
	:								-1
		.2005							-2
		:							
						.1999			
									.III
									-1
		.2005							-2
		.2005	9-8						-3
		.2005	9-8						-4
-8									
								.2005	9
									-5
9 -8									
								.2005	
									-6
		.2004							

	:		-7
.2005			-8
	.2004		
		:	.IV
2003		:	-1
	2000		-2
	:		-3
	.1988		
	2001	20	04- 01
	.2001		-4
		:	.V
.2003			-1
			-2
		2002./2001	
	.2002		-3
	.2003		-4
		:	.VI
	:		-1
http://www. Inrs. Fr.			-2
http://www.annaba.org,p1			-3
http:// www.ipa.edu.sa			-4
http ://www.shura.gov.sa			-5
http:// www.balagh.com			-6
http://www.alsakher.com			-7
http://www.iugaza.edu.			

الملاحق

. /

:

5

-

5

.

-

5

:

5

"

5

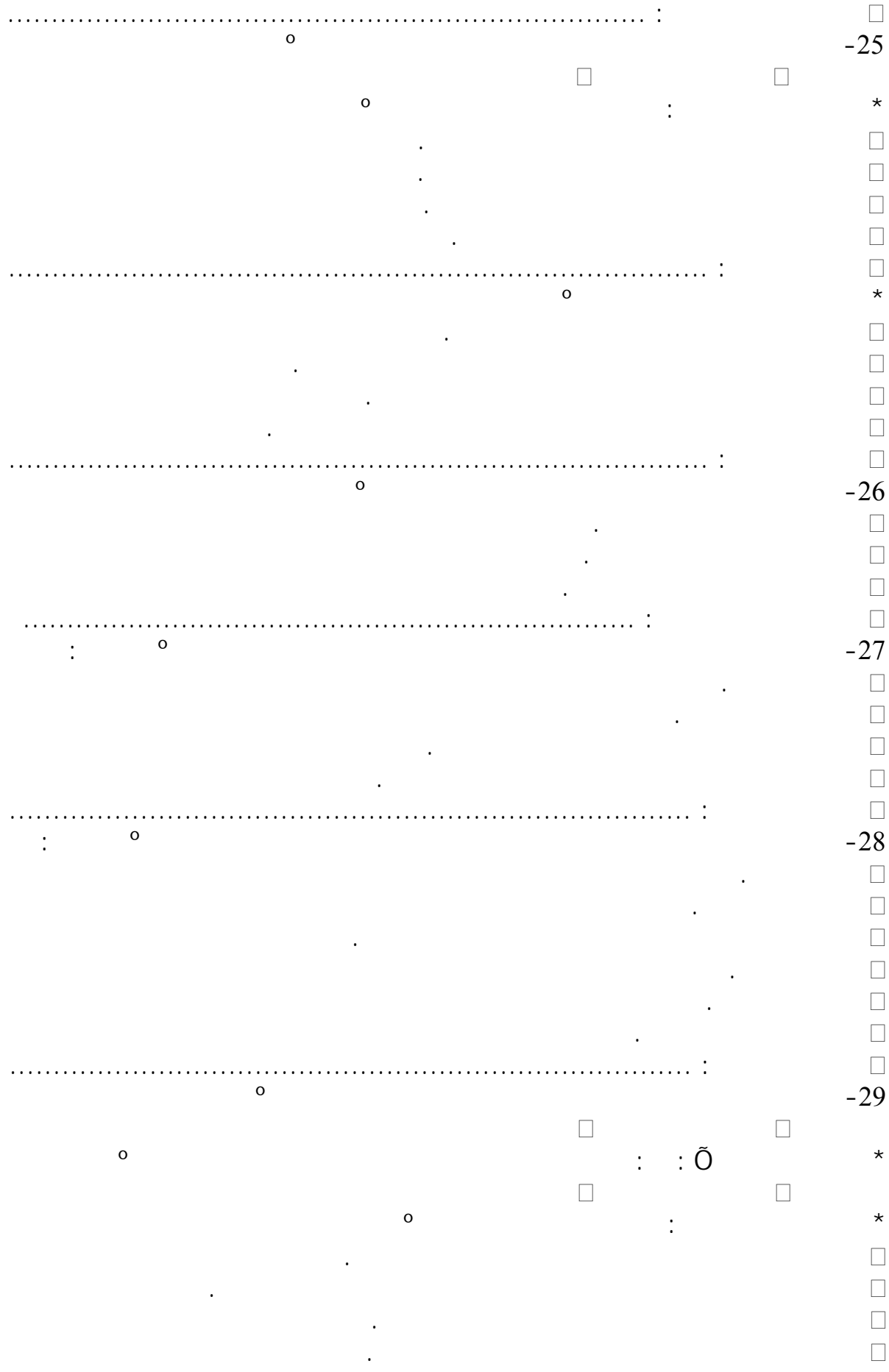

-25
 *

 -26

 -27

 -28

 -29
 *
 *

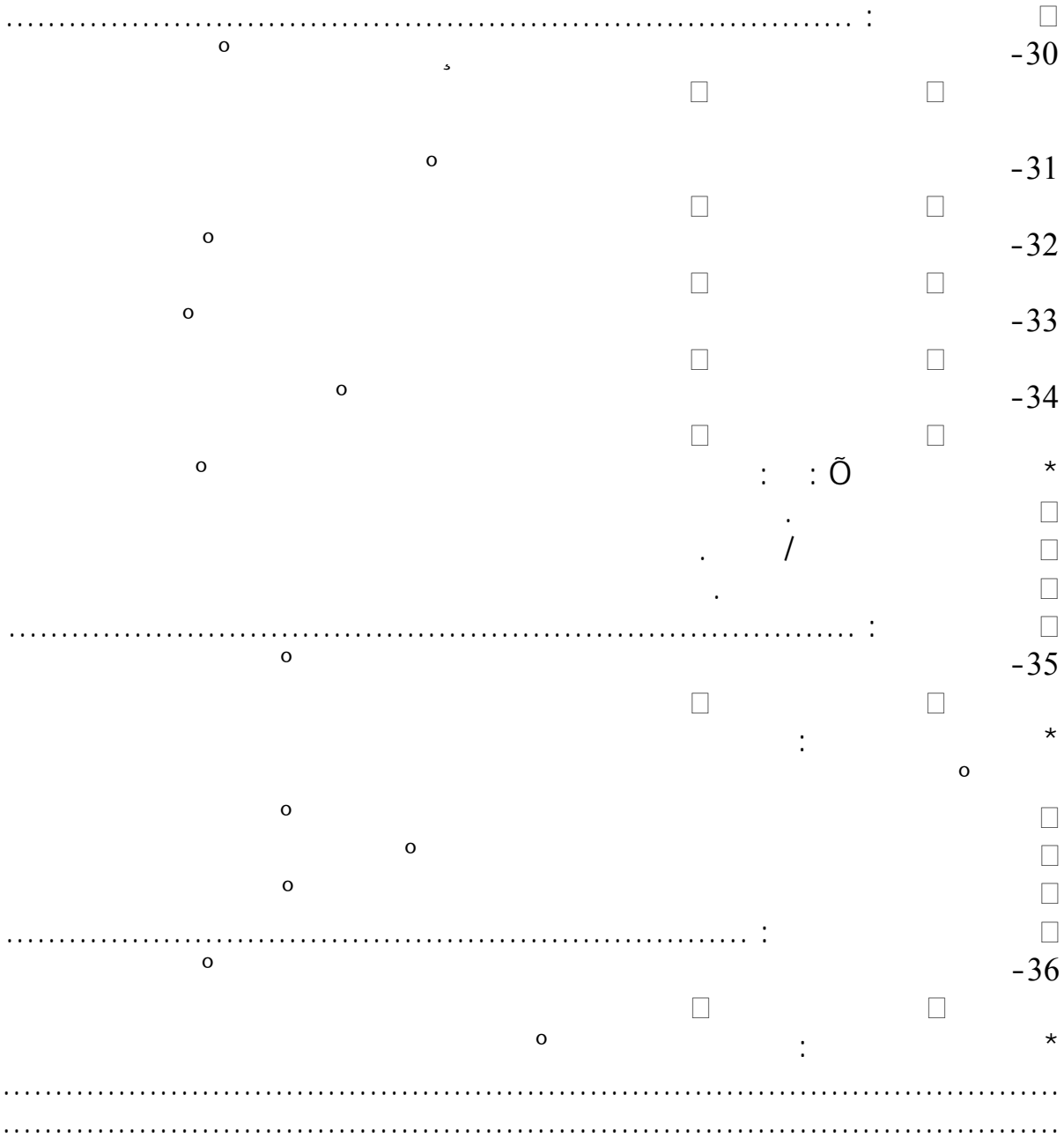



- :
- : -1
- : -2
- . 30 -20
- . 40 -31
- . 50 -41
- . 50
- : -3
- () () ()
- : -4
-
- :
- : () -5
- 15 11 10 5 5 -6
- 20 20 16
- : () -7
- 15 11 10 5 5
- 20 20 16
- : -8
- . 20000 10000
- . 30000 20001
- . 40000 30001
- . 40000

”لتعاونك.